

Be Strong.™



 **NAUTILUS** Service Manual
TreadClimber®, Model TC916
Commercial Series

ATTENTION!

THIS MANUAL IS INTENDED FOR AUTHORIZED NAUTILUS OR NAUTILUS CERTIFIED SERVICE PERSONNEL AND NOT FOR THE CONSUMER. THERE ARE NO USER SERVICEABLE PARTS. SERVICING OF THE NAUTILUS COMMERCIAL SERIES TREADMILL BY OTHER THAN AUTHORIZED NAUTILUS OR NAUTILUS CERTIFIED SERVICE PERSONNEL MAY RESULT IN VOIDING OF THE WARRANTY.

FOR DETAILED INSTRUCTIONS AND INFORMATION ON ASSEMBLY AND USE FOR THE NAUTILUS® COMMERCIAL SERIES TREADCLIMBER®, MODEL TC916, REFER TO THE ASSEMBLY AND OWNER'S MANUALS.



IMPORTANT SAFETY PRECAUTIONS..... 4

PRODUCT SPECIFICATIONS 6

MECHANICAL SERVICE

1.0 Removing The Console 7

2.0 Accessing The Console For Programming 8

3.0 Removing Rear Step 9

4.0 VSD Assembly Grounding 10

5.0 Removing Uprights 12

6.0 Removing Base Plastic 14

7.0 Belt Tension and Alignment 15

8.0 Belt and Deck Replacement 16

9.0 Treadle Adjustment Troubleshooting 18

10.0 Replacement of Pivot Covers 24

11.0 Replacement of Hydraulic Cylinders 26

12.0 Vibration Troubleshooting 28

CARDIO CONSOLE CODES 30

PARTS LIST

Ordering Replacement Parts 33

EXPLODED VIEWS

Working with exploded views 37

Base Frame with Drive Motor 37

Base Frame with VSD Motor Control Board 37

Base Frame with Dependency Link and
Hydraulic System 38

Dependency Link 38

Treadle Assembly 39

Console Upright Assembly, Rear Step and
Console Assembly 39

Base Frame Covers (Right side.) 40

Base Frame Covers (Left side.) 40

Treadle Deck and Belt Assembly (Right side.) 41

Treadle Deck and Belt Assembly (Left side.) 41

Treadle Arm Assembly (Right side.) 42

Treadle Arm Assembly (Left side.) 42

Treadle Covers - Top and Bottom (Right side.) 43

Treadle Covers - Top and Bottom (Left side.) 43

ROC Bar Assembly 44

Console Upright and Cover Assembly 44

Rear Step and Support Platform 45

ELECTRONIC TROUBLESHOOTING

SUMMARY 46

WIRING SCHEMATICS 51

IMPORTANT CONTACT NUMBERS 58

IMPORTANT SAFETY PRECAUTIONS - SAVE THESE INSTRUCTIONS

IMPORTANT SAFETY INSTRUCTIONS

The following definition applies to the word "Warning" found throughout this manual:

WARNING - Used to call attention to POTENTIAL hazards that could result in personal injury or loss of life.

WHEN USING ELECTRICAL EQUIPMENT ALWAYS FOLLOW THESE BASIC PRECAUTIONS:

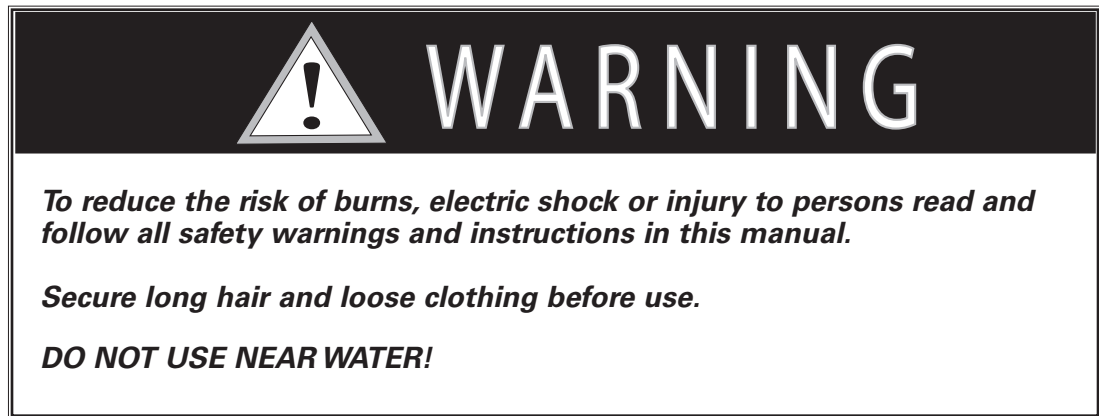

READ ALL INSTRUCTIONS BEFORE USING THE MACHINE.

Read this manual in full before operating the TreadClimber® machine. Failure to follow these guidelines can produce a serious or possible fatal electrical shock hazard or other serious injury. Consult a qualified electrician as required.

1. The controller Stop Key does not turn off the electrical current to the TreadClimber® exercise machine. The TreadClimber® machine continues to draw power, even when the controller is off. To avoid electric shock, do not remove TreadClimber® hood or place hands beneath the TreadClimber® exercise machine while the machine is plugged into a power source.
2. Do not start the TreadClimber® machine when someone else is standing on the walk belts.
3. Keep walk speed and treadle displacement at the lowest settings when getting on and off the TreadClimber® machine.
4. Keep the area underneath and around the TreadClimber® exercise machine clear.
5. Never position the TreadClimber® exercise machine with the back end (direction of belt travel) facing a wall or any other objects such as furniture or other pieces of fitness equipment. Failure to keep the rear space of the machine clear can prevent safe exit of the TreadClimber® machine in an emergency situation such as falling. Allow a minimum of four feet behind the TreadClimber® exercise machine.
6. Before each use of this equipment, check the power receptacle for signs of damage. Do not operate the equipment if the integrity of the power receptacle is in question.

IMPORTANT SAFETY PRECAUTIONS

7. To avoid potential safety and electrical problems, replace with manufacturer's specified parts only.
8. This equipment is classified Class I, Type B, ordinary equipment. Not protected against fluid ingress. Rated for continuous operation. Do not operate this equipment in the presence of flammable anesthetic mixtures.
9. Do not let liquid enter the controller. If it does, the controller must be inspected and tested for safety by an approved technician before it can be used again.
10. Increased risk due to leakage current can result if this equipment is not grounded properly.
11. The TreadClimber® machine must be on an appropriate, dedicated electrical circuit. Nothing else should be connected to the circuit.
12. Do not stand on the TreadClimber® TC916's hood or front trim cover.
13. Close supervision is necessary whenever the machine is used by or near children, invalids, or disabled persons.

Failure to follow the conditions set forth below shall limit, to the extent allowed by law, Nautilus Inc. responsibility for the safety, reliability, and performance of this equipment.

- The Owner's Manual must be read in full by each owner and trainer before the product is first used. Each user must be instructed in the proper use of the TreadClimber® machine and its accessories.
- Do not remove the TreadClimber® hood: dangerous voltages are present. Components are serviceable only by qualified service personnel.
- The electrical wiring within the TreadClimber® equipment setting and the electrical installation of the TreadClimber® machine must comply with the applicable local or provincial requirements.
- The equipment must be used in accordance with the instructions for use.
- For further information or instruction on use, maintenance or specifications, please contact your Authorized Nautilus Fitness Dealer or Service Technician.

PRODUCT SPECIFICATIONS

NOTE: All instructions in the manual are given with the orientation of standing on the TreadClimber® exercise machine facing the console. The console is the front, while the rear step is the back.



Model: TC916

User Weight Capacity:	400 lbs (182 kg)
Speed Range:	0.5 to 6 mph (default set to 4.0 mph) - [.8 to 9.5 km/h (default set to 6.4 km/h)]
Treadle Displacement Levels:	MIN (half the total displacement) and MAX (full treadle displacement)
Walk Surface (W x L):	21" x 48" defined by two separate left and right treadmill belt assemblies (treadles), each treadle 10" x 48" in length, with a 1" or less separation between the belts. (Metric Walk Surface: [53 x 122 cm].)
Floor Space (W x L):	36" x 70" / 91.5 x 178 cm
TreadClimber® Weight:	684 lbs / 310 kg
Shipping Weight:	806 lbs / 366 kg
Power Requirements:	110-120 Volt, 50/60 Hz, 16 amp dedicated circuit. 220-240 Volt, 50 Hz, 10 amp dedicated circuit.
Warranty:	3 years - parts, 1 year - labor, 1 year - wear items, and 15 years - frame and AC-motor. (May vary outside the USA.)

Regulatory Approvals:



C US CSA Certified, UL Listed

Meets:

FCC - Part 15

Canadian ICES-003 Regulations for Class A apparatus



Meets:

Safety - EN 60335-1

EMC Directive 89/336/EEC

Machinery Directive - 98/37/EC

Low Voltage Directive - 89/336/EEC

Patent Information:

U.S. and International Patents Pending

1.0 - REMOVING THE CONSOLE

Tools Needed:

- Phillips head screw driver
- 5/32 Allen bit



WARNING

TO AVOID ELECTRICAL SHOCK OR DAMAGE TO THE UNIT YOU MUST POWER OFF THE UNIT AND MAKE SURE ALL POWER HAS BEEN DRAINED FROM THE UNIT AND CAPACITORS BY ENSURING THERE ARE NO LIGHTED LEDS ON THE CONSOLE.

- 1-1:** Turn off the unit and unplug from the wall outlet.
- 1-2:** Remove Button head screws (P/N- SM24162) on underside of the handles on each side (see Figure 1-1).
- 1-3:** Gently pull console off evenly from both sides until cables are exposed (see Figure 1-2).
- 1-4:** Disconnect the 2 cables on the left side (see Figure 1-3).
- 1-5:** Disconnect the 1 cable on the right side (see Figure 1-4).

NOTE: *To replace console, reverse instructions.*

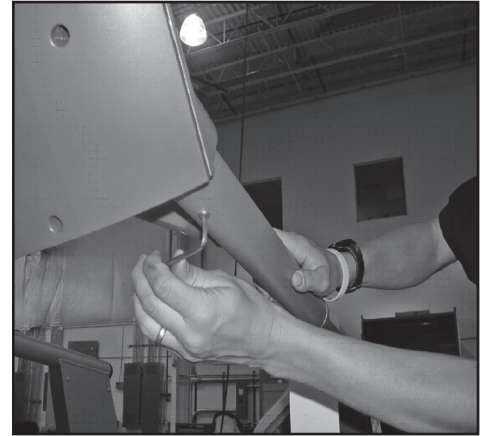

Figure 1-1

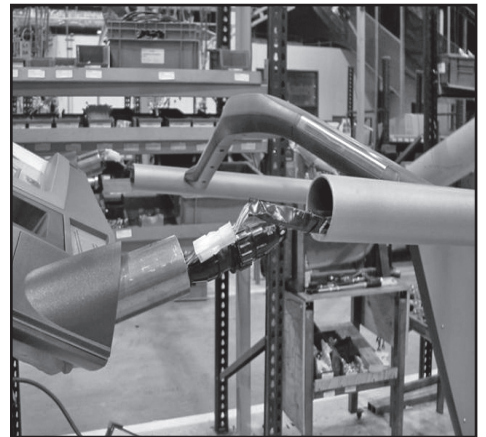

Figure 1-2

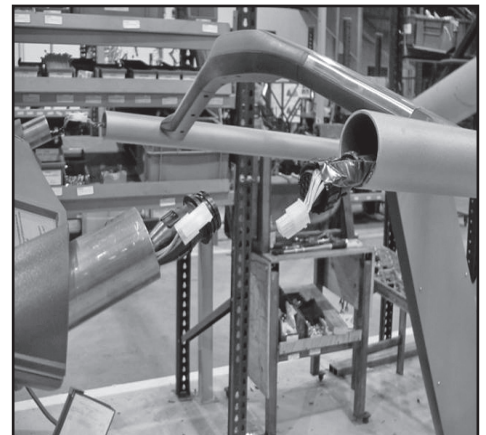

Figure 1-3



Figure 1-4

MECHANICAL SERVICE

2.0 - ACCESSING THE CONSOLE FOR PROGRAMMING

Tools Needed:

- Phillips head screw driver

2-1: Turn off the unit.

2-2: Remove six (6) screws (P/N - SM41271) from back side of console to remove cover and gain access for programming (see Figure 2-1 and Figure 2-2).

2-3: Attach FISP connector for software programming to this connection (see Figure 2-3).

2-4: Turn on the unit.

2-5: The LED on the FISP will blink momentarily, then stay on solid.

2-6: Turn off the unit.

2-7: Remove FISP connector, replace cover and reattach with six (6) screws (P/N - SM41271).

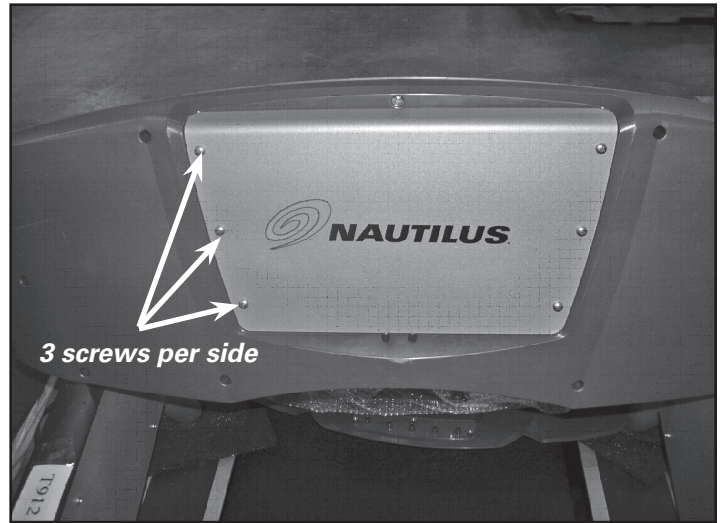

Figure 2-1

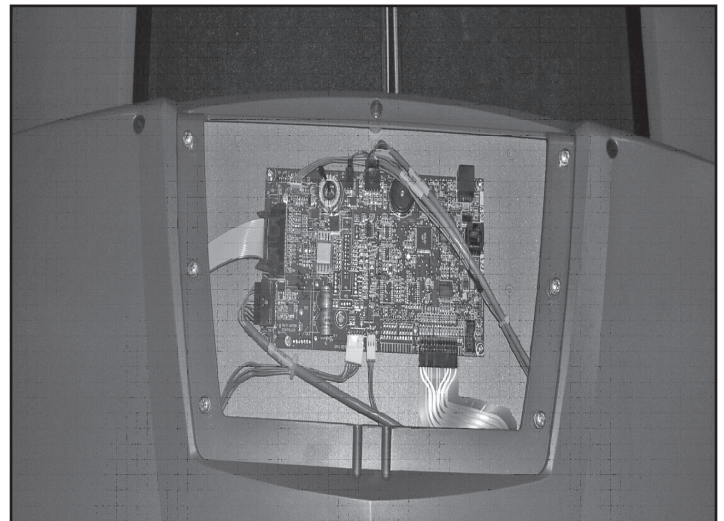

Figure 2-2:
Exposed console circuit board.

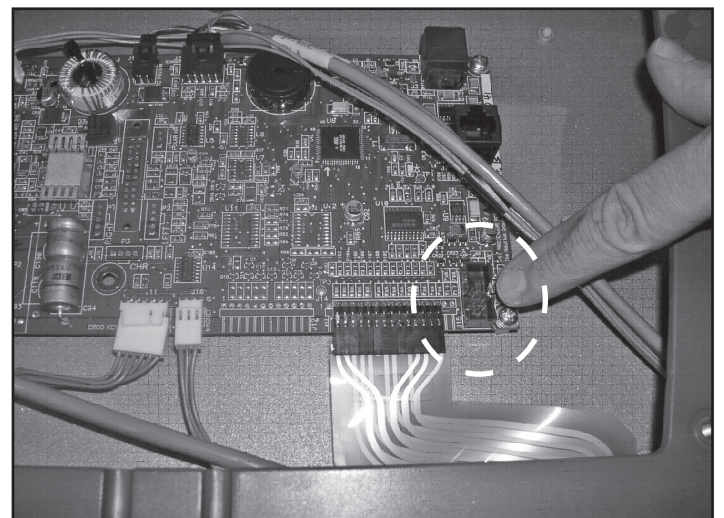

Figure 2-3

3.0 - REMOVING REAR STEP

Tools Needed:

- Phillips head screw driver
- 5/32 Allen bit



WARNING

TO AVOID ELECTRICAL SHOCK OR DAMAGE TO THE UNIT YOU MUST POWER OFF THE UNIT AND MAKE SURE ALL POWER HAS BEEN DRAINED FROM THE UNIT AND CAPACITORS BY ENSURING THERE ARE NO LIGHTED LEDS ON THE CONSOLE.

- 3-1:** Unplug the unit from the power source and ensure that all power has been drained from the unit.
- 3-2:** Remove two (2) middle screws from Rear Step Cover (see Figure 3-1).
- 3-4:** Lift and slide step cover plate back to remove (see Figure 3-2).
- 3-3:** Remove four (4) screws from Step Weldment (see Figure 3-3).
- 3-5:** Replace rear cover by sliding back into place and re-installing four (4) outer screws.
- 3-6:** Place Step cover onto Step weldment and reattach with two (2) screws (see Figure 3-2 and Figure 3-1).

Removing the step cover plate provides access to the I/O cables needed for the removal of the uprights.



Figure 3-1

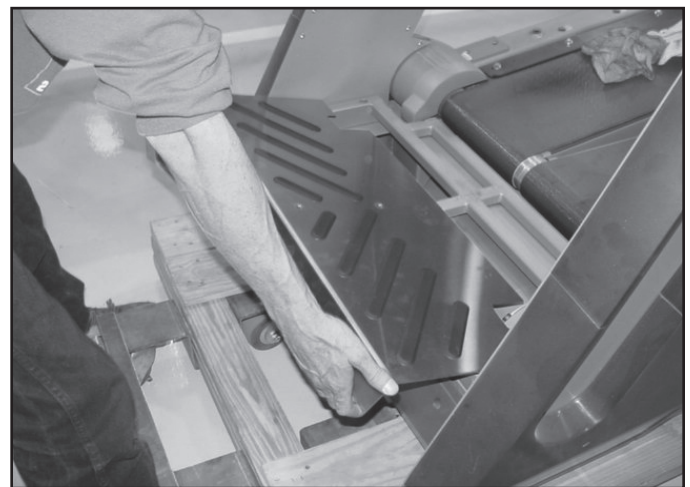

Figure 3-2

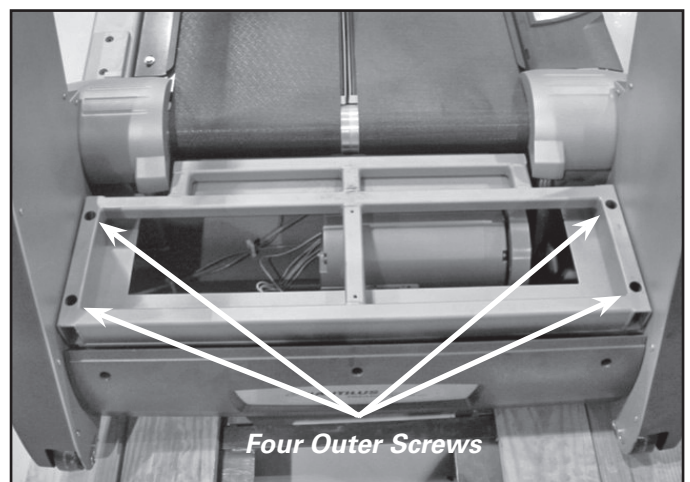

Figure 3-3

4.0 - VSD ASSEMBLY GROUNDING

Parts Affected:

- Front Trim Cover - P/N: SM17652
- Right Pan Cover - P/N: SM17653
- Right Side Cover - P/N: SM17655
- VSD Assembly, TC916 - P/N: SM17688
- Flat Washer, 1/4 ID x 5/8 OD - P/N: SM22047
- Screw, .250-20 x .75, HX Wash HD - P/N: SM27594

Tools Needed:

- 1/8 Allen Bit
- 3/8 inch Socket or Open End Wrench

Figure 1:



WARNING

To avoid the risk of electrocution, shock or mechanical injury, before performing this maintenance, ensure that the machine is unplugged.

To Install New VSD Ground Improvement:

- 4-1:** Adjust Right Treadle to maximum step height.
- 4-2:** Remove three (3) screws from Front Trim Cover (P/N - SM17652). See Figure 1.
- 4-3:** Remove four (4) screws from Right Side Cover (P/N - SM17655). See Figure 2.
- 4-4:** Remove two (2) screws from Right Pan Cover to access the VSD Assembly (see Figure 3 and Figure 4).

CAUTION: ENSURE THAT ALL LIGHTS ARE OFF ON THE VSD ASSEMBLY BEFORE CONTINUING - OTHERWISE, YOU MAY DAMAGE THE BOARD.

- 4-5** Disconnect and mark cables (for reconnecting in later step) from the VSD board.

Figure 2:



- 4-6:** Remove the two (2) VSD Bracket Screws (P/N - SM27594), then remove the VSD Assmebly (see Figure 4).
- 4-7:** Position the new VSD Assembly in place and attach with the two (2) bracket screws.
- 4-8:** Reconnect the previously marked cables to the VSD Assembly.
- 4-9:** Reattach all covers and verify that all machine functions are working properly.

Figure 3:



Figure 4:

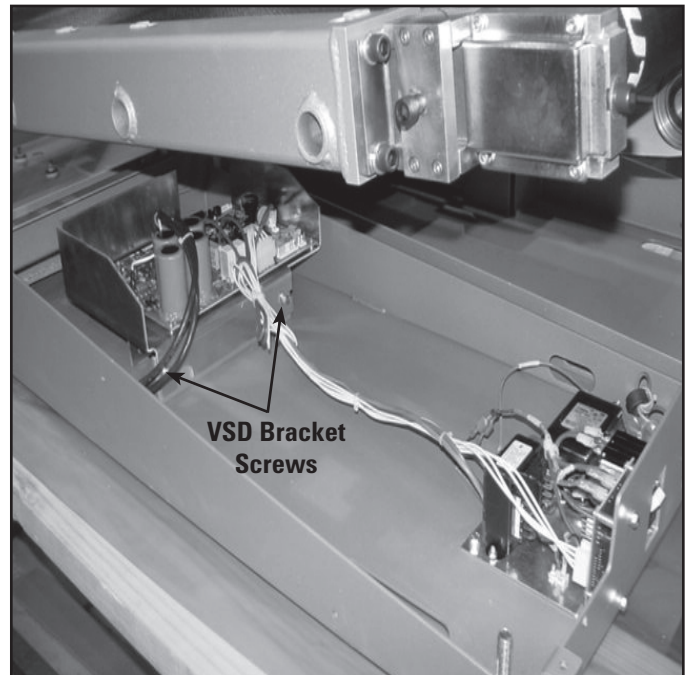

5.0 - REMOVING UPRIGHTS

Tools Needed:

- 1/8 Allen bit
- 5/32 Allen bit
- 3/4 inch Socket
- Phillips head screw driver

WARNING

DETACHING AND MOVING THE UPRIGHT PORTION OF THIS PRODUCT REQUIRES TWO PEOPLE! YOU MUST HAVE A MINIMUM OF TWO PEOPLE TO PROPERLY SUPPORT THE HEAVY UPRIGHT STRUCTURE SO THE CONSOLE DOES NOT FALL AND CAUSE DAMAGE TO THE UNIT.

WARNING

TO AVOID ELECTRICAL SHOCK OR DAMAGE TO THE UNIT YOU MUST POWER OFF THE UNIT AND MAKE SURE ALL POWER HAS BEEN DRAINED FROM THE UNIT AND CAPACITORS BY ENSURING THERE ARE NO LIGHTED LEDS ON THE CONSOLE.

5-1: Remove the Front Trim Cover (P/N - SM17652), Left Side Cover (P/N - SM17656), Left Pan Cover (P/N - SM17654) and Right Side Cover (P/N - SM17655), Right Pan Cover (P/N - SM17653).

5-2: Remove the Rear Step Cover and weldment (see Figure 5-1).

5-3: Remove the Rear Plastic Cover (P/N - SM17659 to access the Upright Cables. (See Figure 5-2 and Figure 5-4.)

5-4: Disconnect three cables as follows:

A) From the VSD Board. See Figure 5-3.

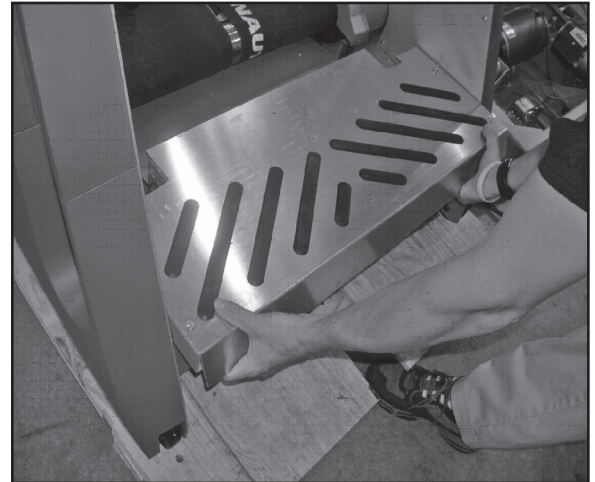

Figure 5-1

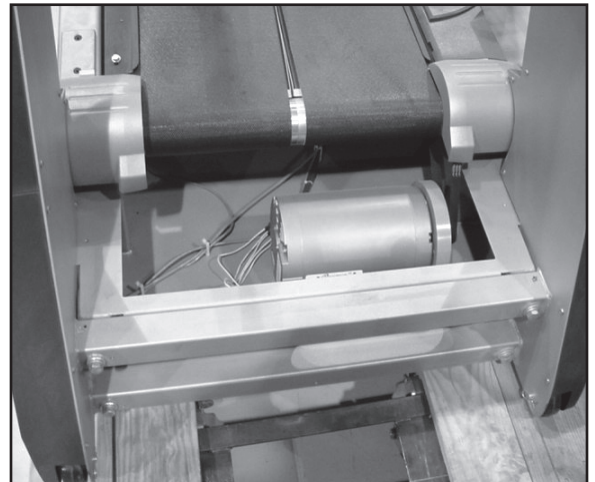

Figure 5-2

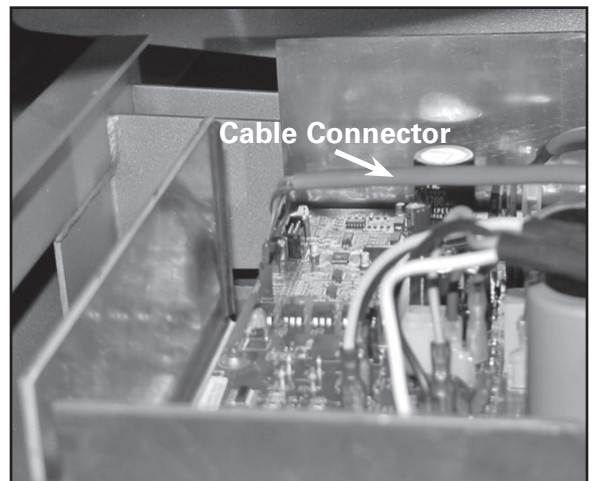

Figure 5-3: I/O Connectors.

B) From the Encoder Assembly PC board (Not shown).

NOTE: The Encoder is under the Treadles and you will have to reach into the machine to disconnect.

C) From the Hydraulic Cylinder. See Figure 5-5.

5-5: Remove the Right Lower Cover (P/N - SM17657) and Left Lower Cover (P/N - SM17658). See Figure 5-6 and 5-7.

5-6: Remove four (4) upright weldment bolts (see Figure 5-8).

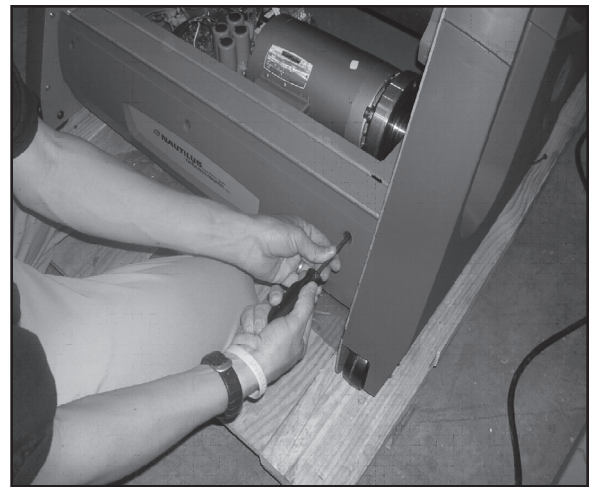

Figure 5-4

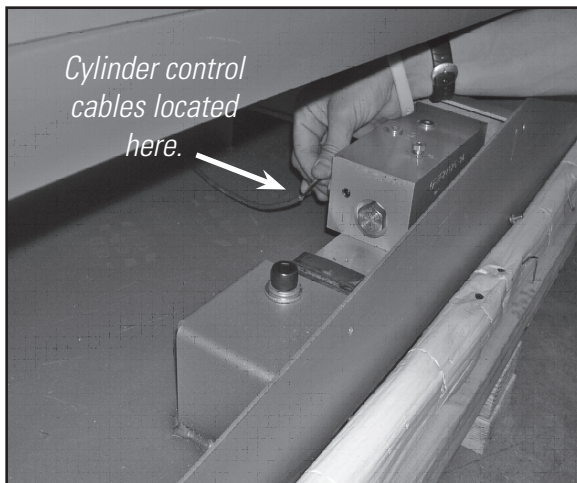

Figure 5-5



Figure 5-6: Lower plastic parts.



Figure 5-7

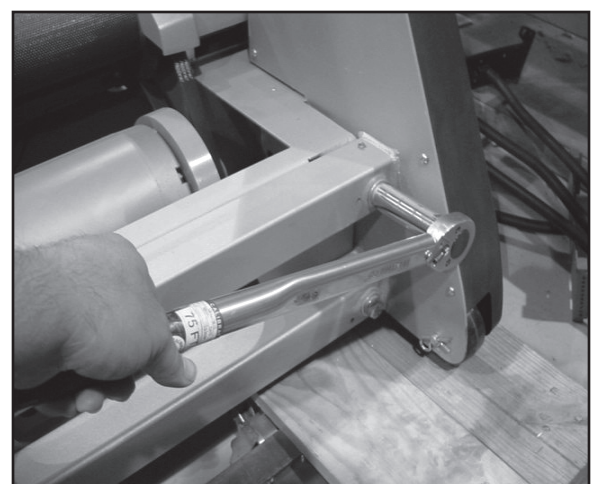

Figure 5-8

6.0 - REMOVING BASE PLASTIC

Tools Needed:

- Phillips head screw driver
- 1/8 Allen bit



WARNING

TO AVOID ELECTRICAL SHOCK OR DAMAGE TO THE UNIT YOU MUST POWER OFF THE UNIT AND MAKE SURE ALL POWER HAS BEEN DRAINED FROM THE UNIT AND CAPACITORS BY ENSURING THERE ARE NO LIGHTED LEDS ON THE CONSOLE.

- 6-1:** Remove three (3) front plastic screws (see Figure 6-1).
- 6-2:** Remove right and left side plastic covers - four (4) screws each side (see Figure 6-2).
- 6-3:** Remove right and left side pan covers - two (2) screws each side (see Figure 6-3 and Figure 6-4).

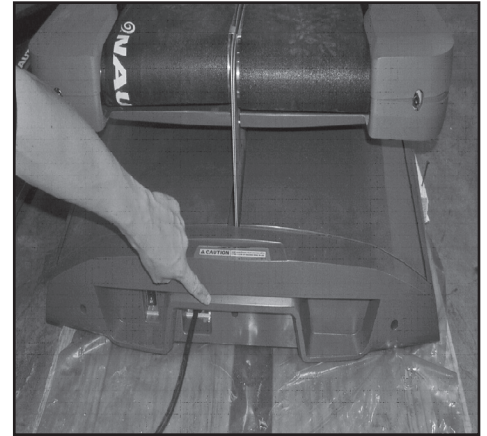

Figure 6-1



Figure 6-2



Figure 6-3

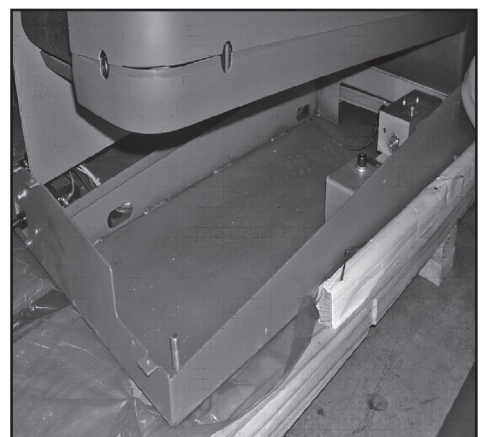

Figure 6-4:
Pan without covers.

7.0 - BELT TENSION AND ALIGNMENT

Parts Affected:

- Left Treadle Assembly - P/N 17623
- Right Treadle Assembly - P/N 17617
- Treadle Belt - P/N - SM17860

Tools Needed:

- 5/16 Allen bit

Belt alignment and tensioning adjustments (see Figure 1).

NOTE: See Figure 1 for belt and tensioning adjustment screws. The adjustments are the same on the right and left side of the machine.

To check for proper belt alignment:

7-1: Operate TreadClimber® machine so belt is running at 2.5 - 3 mph (4 - 4.8 km/h).

7-2: Belt is aligned when 1/8" (3.2 mm) of roller is showing (see Figure 2).

7-3: Tightening alignment screw clockwise moves belt out, loosening screw counter-clockwise moves belt in.

To check for proper belt tension:

7.1-1: Tension is correct when the gap between the treadles is even and centered. See Figure 3 for an example of INCORRECT tension.

7.1-2: Tighten (clockwise turn) or loosen (counter-clockwise turn) tensioning adjustment located at the end of the treadle.

To completely loosen belt if you want to start from scratch:

7.2-1: Totally loosen alignment screw by turning counter-clockwise.

7.2-2: Loosen tensioning screw by turning counter-clockwise.

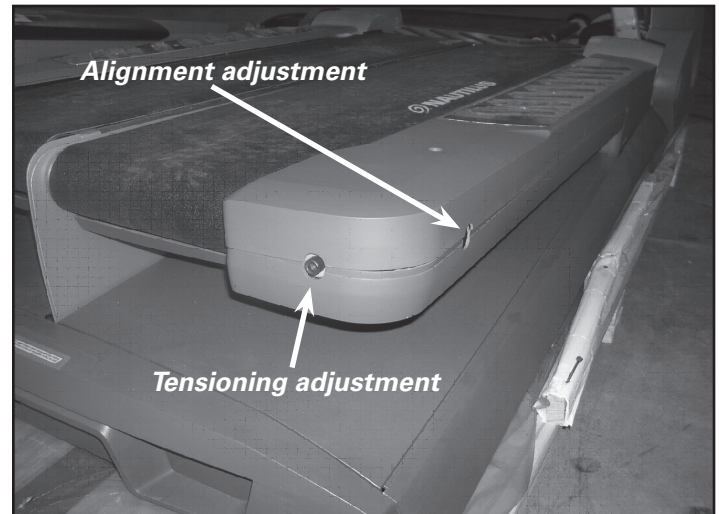

Figure 1

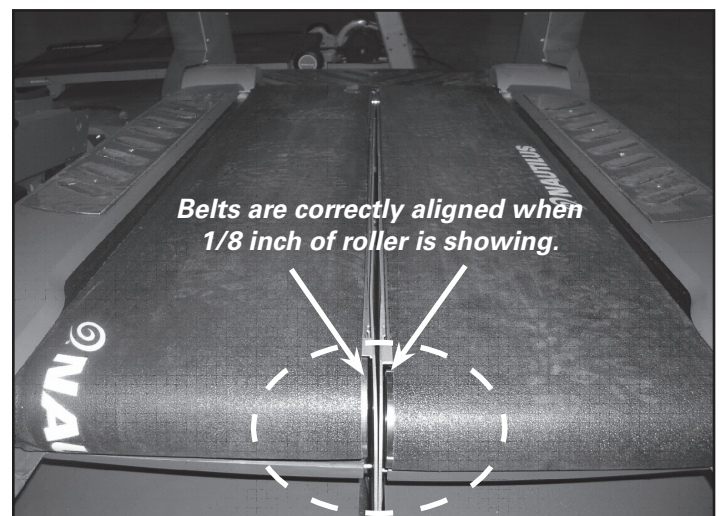

Figure 2

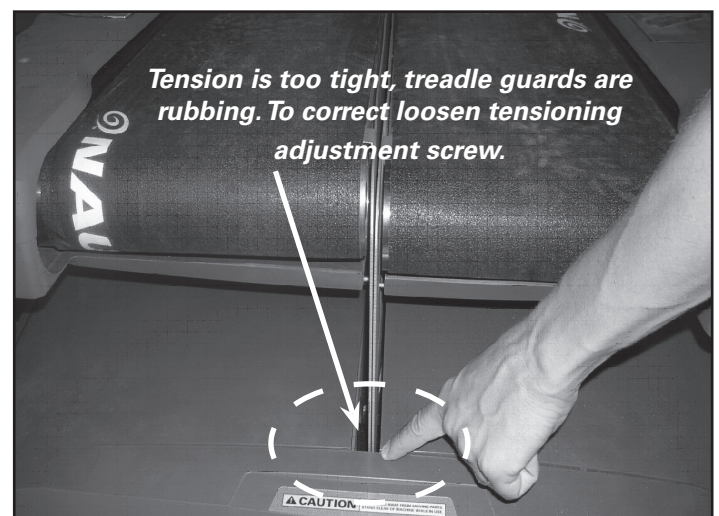

Figure 3

8.0 - BELT AND DECK REPLACEMENT

Tools Needed: 7/16 & 3/4 Wrench or Socket
3/8 Allen Socket
1/8, 5/32 & 5/16 Allen Wrench
Phillips screwdriver
wood blocks 4-6 inch (10-15 cm) thick

- 8-1:** Remove rear cover and rear step (see Figure 1 and Figure 2).
- 8-2:** Remove side pivot covers, side frame covers, front cover, bottom frame covers and treadle covers (see Figure 1).
- 8-3:** Loosen four 1/2" - 13 bolts holding uprights to frame using 3/4 socket or wrench.
- 8-4:** Remove pivot casting bolts with 5/32 Allen wrench.
- 8-5:** Lift console upright to remove pivot castings.
- 8-6:** Relieve all tension on the belt by completely loosening the alignment screw and then the tensioning screw.
- 8-7:** Remove end casting with front roller using 5/16 Allen wrench (see Figure 3).
- 8-8:** Remove deck screws with a 7/16 socket or wrench.
- 8-9:** Remove deck (see Figure 4).
- 8-10:** Brace treadles with blocks 4-6 inches (10-15 cm) thick (see Figure 5).
- 8-11:** There are 2 treadle bolts and 4 treadle pivot bolts on each side. Remove these 6 bolts on one side, and loosen the 2 treadle bolts and remove the 4 pivot bolts using a 3/8 Allen and socket wrench (see Figure 6).

NOTE: Remove one belt at a time. Replace the bolts, deck and belt before proceeding to the other side.

- 8-12:** Lift treadle to create clearance for walk belt to slide between upright and end of roller (see Figure 7).
- 8-13:** Replace belt and deck using the reverse order of steps 11 through 1.

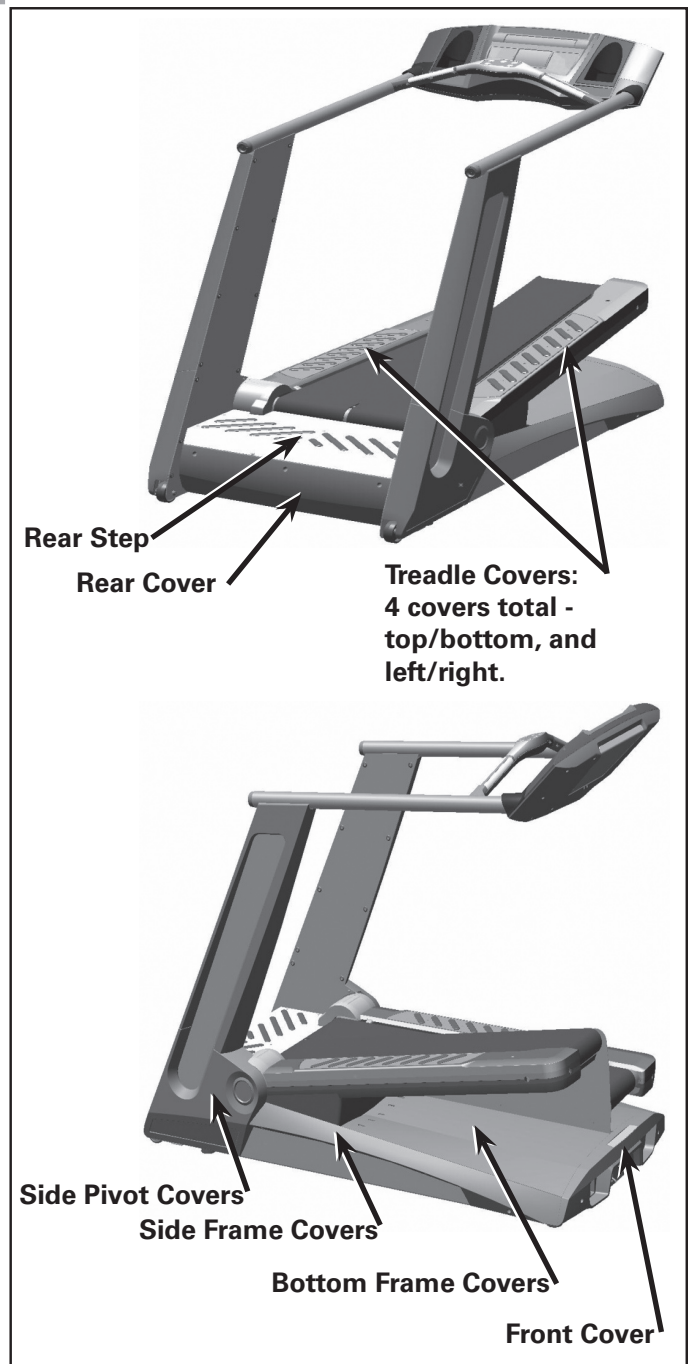

Figure 1



WARNING

ALWAYS UNPLUG THE TREADCLIMBER® BEFORE PERFORMING ANY TREADLE REPAIR!
USE CAUTION WHEN WORKING ON THE DECK OR REPLACING THE BELTS. SERIOUS INJURY TO FINGERS AND HANDS MAY OCCUR IF THE TREADLES ARE NOT PROPERLY SUPPORTED WITH BLOCKS.

BELT AND DECK REPLACEMENT CONTINUED:

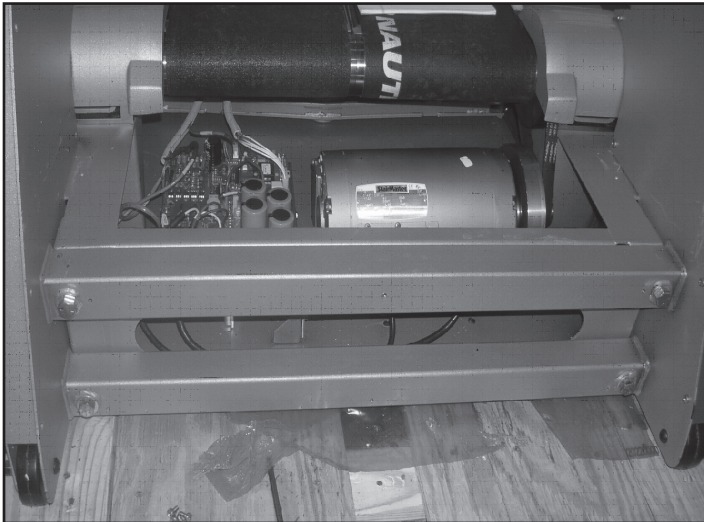

Figure 2: Rear cover and rear step removed.

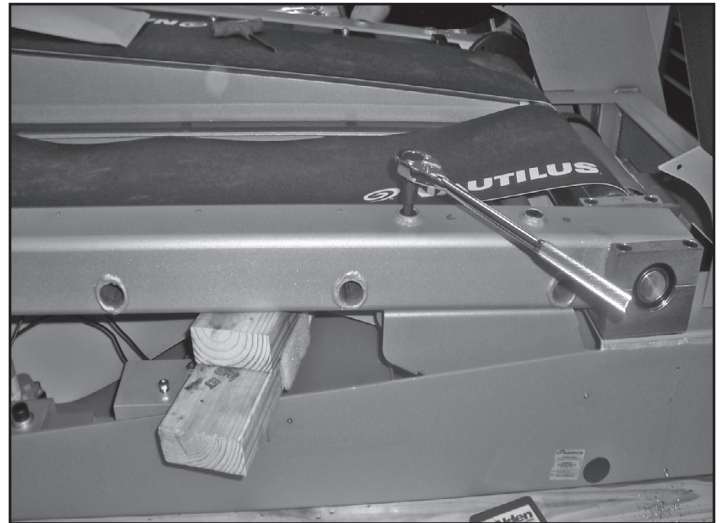

Figure 5: Brace treadles with wooden blocks.

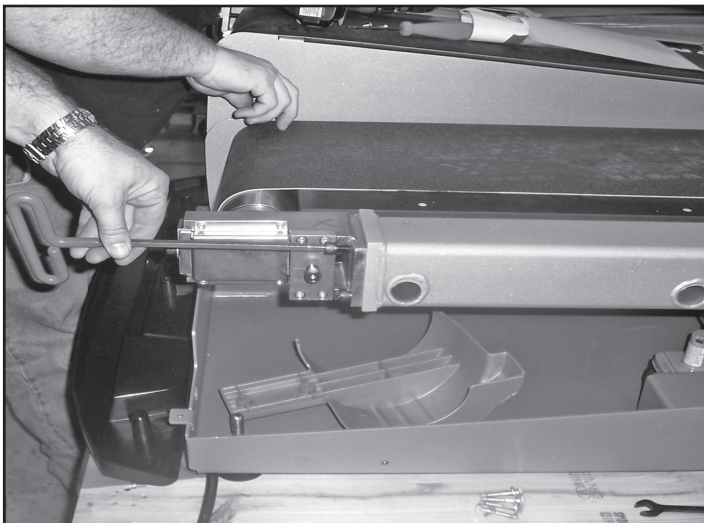

Figure 3: Removing end casting with Allen wrench.

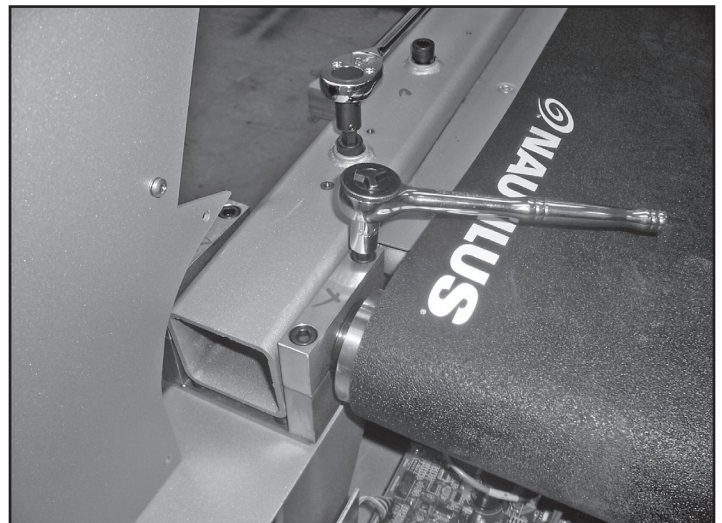

Figure 6: Remove treadle bolts & pivot bolts; 4 bolts per side.

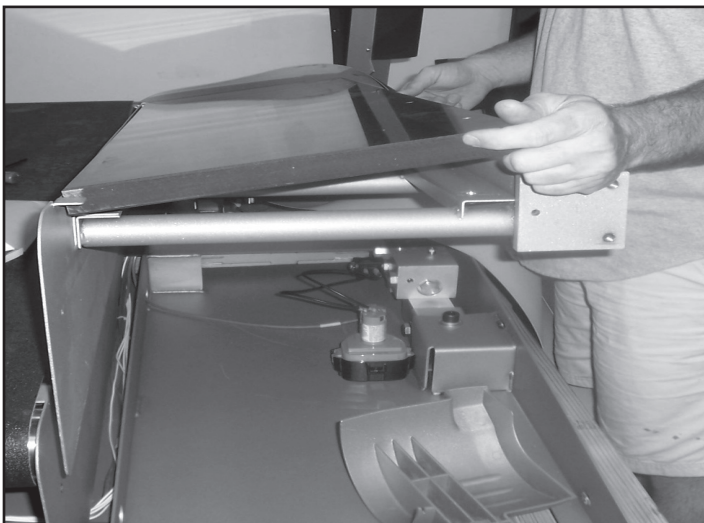

Figure 4: Remove deck.



Figure 7: Lift treadle to create clearance.

9.0 - TREADLE ADJUSTMENT TROUBLESHOOTING

Parts Affected:

- Treadle Assembly
- Hydraulic Cylinder

Tools Needed:

- Phillips Screwdriver
- Hex Key
- Socket Wrench
- Flat Screwdriver

Troubleshooting Treadle Steps:

A DETERMINING IF THERE IS A PROBLEM WITH THE HYDRAULIC CYLINDER (EITHER AIR IN THE SYSTEM OR CONTAMINANTS IN THE OIL AND VALVES), OR IN THE CONNECTING HARDWARE:

NOTE: *Two people are required to complete this step. One person standing on the treadles, while the other person adjusts the encoder.*

9A-1: Disconnect the two leads from the hydraulic cylinder. This will ensure that the hydraulic cylinder valve should be closed (see Figure A-1).

9A-2: With the treadles in the locked position, pull up and down on both the right and left treadles (see Figure A-2).

If the right treadle is loose (moves more than ½") and the left treadle is solid, this points to loose hardware. Go to Step 9A-4 in Section A.

If both right and left treadles are loose, then the problem could be loose hardware or a bad cylinder.

Figure A-1

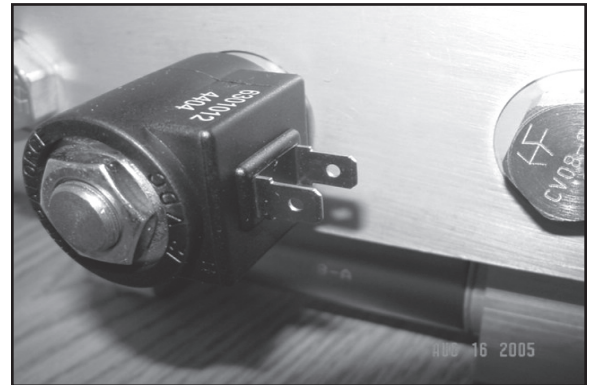

Figure A-2



Figure A-3

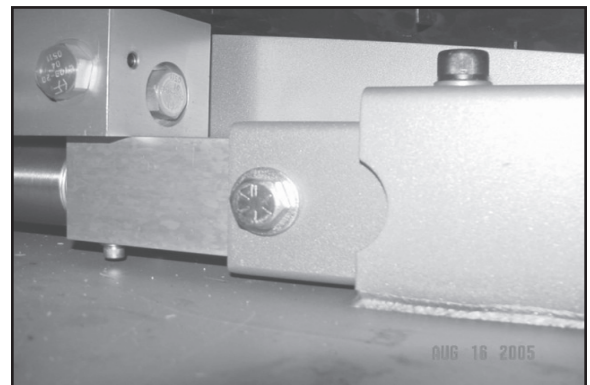
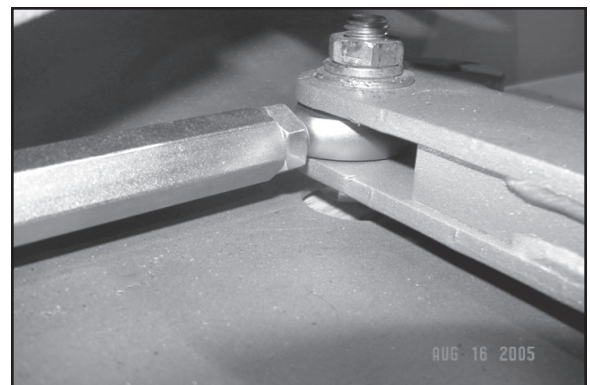

Figure A-4



9A-3: Check the cylinder by feeling the shaft of the cylinder and pulling up and down on the left treadle. If the cylinder shaft moves in and out of the cylinder body by more than an 1/8th inch (3.2 mm), then the cylinder will need to be replaced.

9A-4: If the problem is not in the cylinder, then check the hardware at the following locations and tighten as necessary:

- a) On the rod-end entering the cylinder, the jam nut should be tight to the rod-end, and there should only be 2 or 3 threads showing on the opposite side of the jam nut. This insures that the rod-end is fully engaged in the cylinder.
- b) The connection between the rod-end and the dependency weldment. See Figure A-6. Tighten as necessary.
- c) The connection between the dependency and the rod-end on the opposite (right) side (see Figure A-4 and A-5).
- d) The center bolt at the center of the dependency weldment (see Figure A-6).
- e) Check both the horizontal and the vertical bolts connecting the cylinder to the coupler and the coupler to the weldment of the pan. The bolts should be torqued to 75 ftlbs (105 Nm). See Figure A-7.

Figure A-5

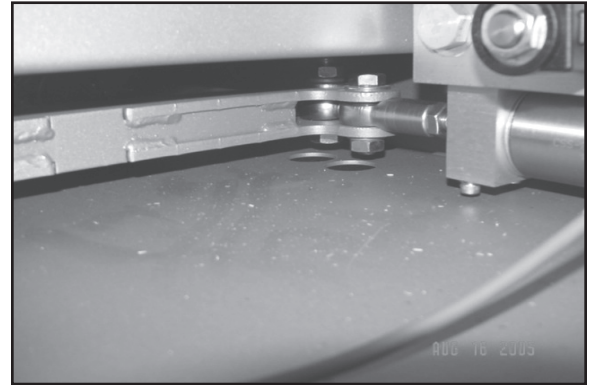

Figure A-6

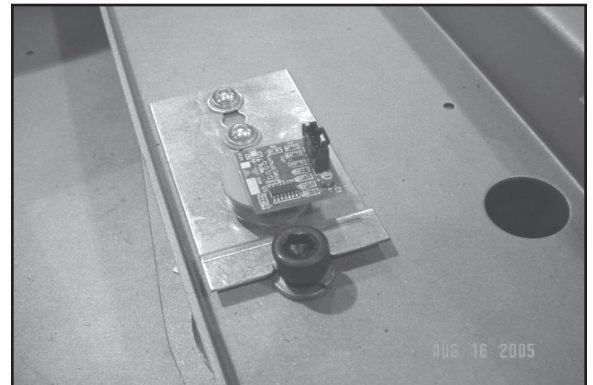
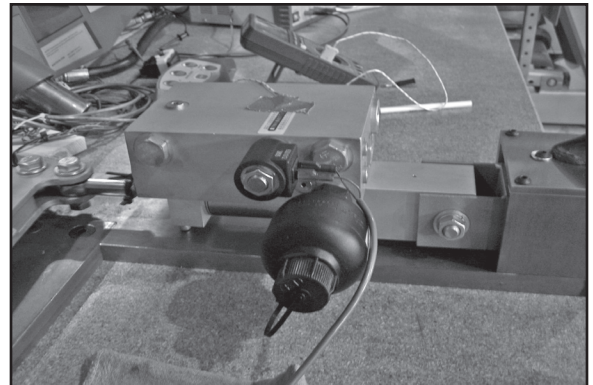

Figure A-7



B ■ IF THE PROBLEM IS NOT IN THE HYDRAULIC CYLINDER OR THE CONNECTING HARDWARE, THEN PERFORM THE FOLLOWING ELECTRONIC AND SOFTWARE CHECKS:

- 9B-1:** Turn the unit on. Move the treadles up and down until they come to a locked position.
- 9B-2:** If the treadles do not come to a locked position within 2 to 4 steps, then position the treadles level. Turn the power off. Wait 10 seconds, then turn the power on. Move the treadles up and down until they come to a locked position.
- 9B-3:** If the treadles still do not come to a locked position, then check the treadle center position on the encoder PCB, as follows:
- Remove the rear step. Enter diagnostic mode. From the Intro screen, press [Speed UP] [6] [ENTER]. The display will read "DIAGNOSTIC".
 - Press the [Speed UP] or [Speed DOWN] keys to scroll through the options until "TREADLE CENTER" is displayed. Press [ENTER]. This will release the treadles to allow them to be moved by hand.
 - Slowly move the treadles up and down while looking at the encoder PCB mounted in the center of the dependency mechanism. There is a light on the PCB. Note the position of the treadles when the light on the PCB comes on. The treadles should be parallel within 1 inch (2.5 cm) of each other when the PCB light comes on (see Figure B-1).
 - If the treadles are not parallel when the encoder PCB light comes on, then the large encoder wheel will need to be adjusted. Go to section C of this section in the Service Manual to re-center the encoder wheel. Be sure to verify that the large encoder wheel is firmly fixed to the dependency

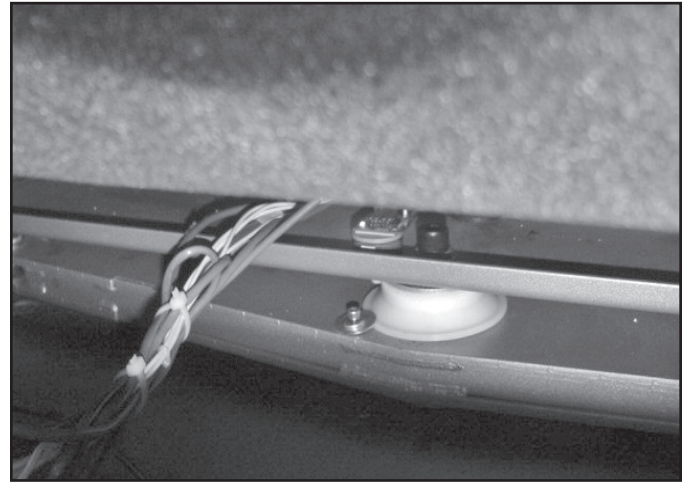

Figure B-1

mechanism. This can be checked by verifying the number of encoder counts in the diagnostic software. See section D of this bulletin to check the encoder counts.

- e) If the treadles are parallel or within 1 inch of parallel when the encoder PCB light comes on, reset the treadle center in the software mode. Go to Section E of this bulletin to reset the treadle center in the software mode.

C TO RE-CENTER THE LARGE ENCODER WHEEL ATTACHED TO THE DEPENDENCY MECHANISM, FOLLOW THESE STEPS:

9C-1: Loosen the set screw. Be sure that the treadles are level.

9C-2: **SLOWLY** rotate the large encoder wheel in one direction by hand or use a small flat-blade screwdriver on the teeth of the encoder wheel. Rotate the wheel until the light comes on the encoder PCB.

9C-3: With the treadles level and the encoder light on, tighten the set screw holding the large encoder wheel in place (see Figure C-1).

9C-4: Go to section D to make sure that the large encoder wheel is not slipping during treadle movement.

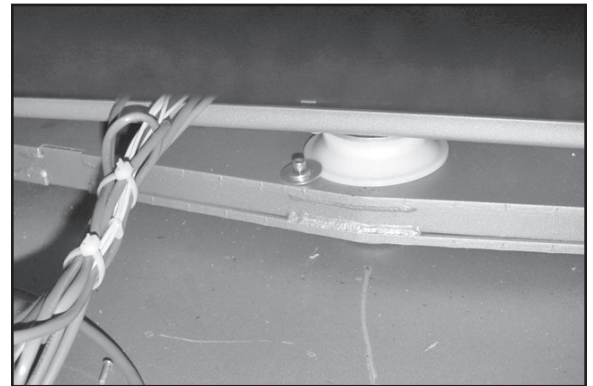

Figure C-1

D

TO CHECK THE ENCODER RANGE OF MOVEMENT AND TO MAKE SURE THE LARGE ENCODER WHEEL IS NOT SLIPPING DURING MOVEMENT, FOLLOW THESE STEPS:

- 9D-1:** From the Intro screen, press [Speed UP] [6] [ENTER]. The display will read "DIAGNOSTIC". Press the [Speed UP] or [Speed DOWN] keys to scroll through the options until "TREADCLIMBER" is displayed. Press [ENTER].
- 9D-2:** The top line of the display will read: "ENCODER - XX" (see Figure D-1). Press the [9] key. The PWM value, which is on the lower line center position, will change from 255 to 189, and the treadles will be free to move up and down.
- 9D-3:** Shift your weight to the left side, allowing the left treadle to fall all the way to the bottom. With the left treadle held at the bottom, note the number displayed on the top line, far right. It should read in the range between [- 30] and [- 50]. Remember the number.
- 9D-4:** Next, shift your weight to the right side, allowing the right treadle to fall all the way to the bottom. The number displayed on the top line, far right should read in the range between [30] and [50]. Remember the number.
- 9D-5:** Calculate the total range between the two numbers. The absolute value of the negative number (left side down) added to the positive number (right side down), represents the total encoder range of motion. This number should be in the range between 70 and 90 total counts.
- 9D-6:** If the range is less than 70, check to make sure the large encoder wheel is not slipping.

Figure D-1



To check if the encoder wheel is slipping, slowly move the treadles up and down. The encoder value displayed will hesitate and not count up or down. In other words, the encoder value will not change, even though there is movement in the treadles. If the encoder value does not change during movement of the treadles, then the encoder wheel is slipping and needs to be tightened or replaced.

E ■ TO RESET THE TREADLE CENTER ■ IN SOFTWARE TO MATCH THE ■ TREADLE CENTER ON THE ENCODER, FOLLOW THESE STEPS:

- 9E-1:** From the Intro screen, press [Speed UP] [6] [ENTER]. The display will read "DIAGNOSTIC". Press the [Speed UP] or [Speed DOWN] keys to scroll through the options until "TREADLE CENTER" is displayed. Press [ENTER].
- 9E-2:** The top line of the display will read: "VIRTUAL CENTER - XX" (see Figure E-1). With the treadles held parallel, press the [STOP] key. The number on the display will be used by the software for the center point position. When STOP key is pressed the number will change to a value between 0 to 255. This means the treadle center in the software has been recalibrated to match the center position of the encoder.
- 9E-3:** Press [CLEAR] twice to exit the Diagnostic mode. Move the treadles up and down until the treadles lock. Verify that the treadles lock parallel to each other or within 1" of parallel.
- 9E-4:** If the treadles do not lock parallel or close to parallel, then 1) recheck the center position on the encoder PCB (section B); 2) recheck the encoder range (section D); 3) recheck the treadle center in software (section E).



Figure E-1

10.0 - REPLACEMENT OF PIVOT COVERS

Parts Affected:

- Right Pivot Cover - P/N 17660
- Left Pivot Cover - P/N 17661

Tools Needed:

- 3/16 Allen Wrench
- 5/32 Allen
- 1/8 Allen
- Phillips Screwdriver
- 3/4 inch Socket
- 3/4 inch Wrench or Open Ended Wrench
- Wedge support or flat head screwdriver to use as a wedge

See Figure 1 for Steps 10-1 thru 10-4.

10-1: Remove Rear Step (P/N -17733) and Step Plate (P/N - 17591).

10-2: Remove Rear Plastic Cover (P/N - 17659).

10-3: Remove right Treadle Cover (P/N - SM17731 and P/N - SM17666), then remove the left Treadle Cover (P/N - SM17332 and P/N - 17667).

10-4: Remove right and left Upright Lower Plastic Pivot Covers (P/N - SM17657 and P/N - 17578).

Figure 1

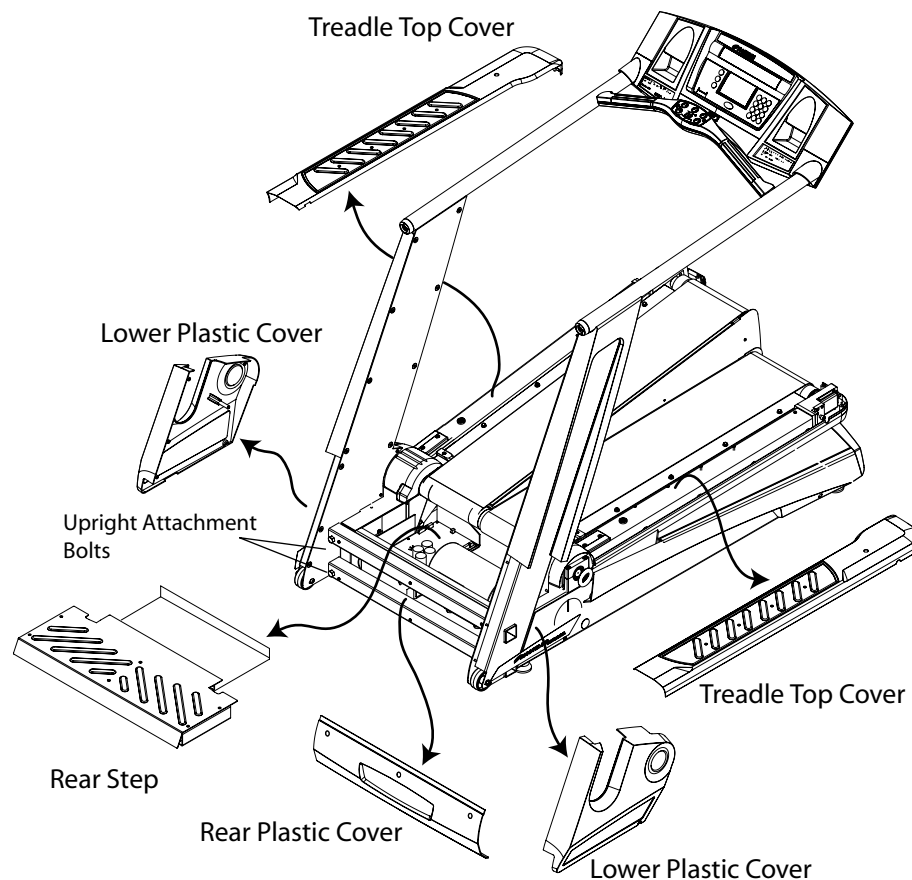

10-5: Loosen 4 inside bolts (2 on each side) that attach the upright (P/N - 17626) to base frame (see Figure 2).

CAUTION

DO NOT REMOVE BOLTS COMPLETELY. TO DO SO WILL CAUSE THE UPRIGHT SUPPORTS TO FALL RESULTING IN DAMAGE TO THE UNIT AND POSSIBLE INJURY TO BYSTANDERS. THE BOLTS MUST NOT BE BACKED BEYOND A MAXIMUM DISTANCE OF 1/2 INCH. SEE FIGURE 2.

10-6: Slide the upright (P/N - 17626) backwards, away from the front of the unit to expose the right and left pivot covers. Secure in the back position (see Figures 1 & 2).

CAUTION

SLIDING THE UPRIGHTS MAY REQUIRE ASSISTANCE. DO NOT ATTEMPT TO LIFT THE UNIT.

10-7: Remove right and left pivot covers (P/N - 17660 & 17661). This may require a twisting motion (see Figure 3). Install replacement pivot cover in its place.

10-8: Reassemble the unit in reverse order from Step 6 to Step 1: Slide the uprights forward into place; tighten the four inside bolts; reinstall the right and left lower plastic covers; reinstall the right and left treadle top covers; reinstall rear plastic cover; and reinstall rear step and step plate weldment.

Figure 2

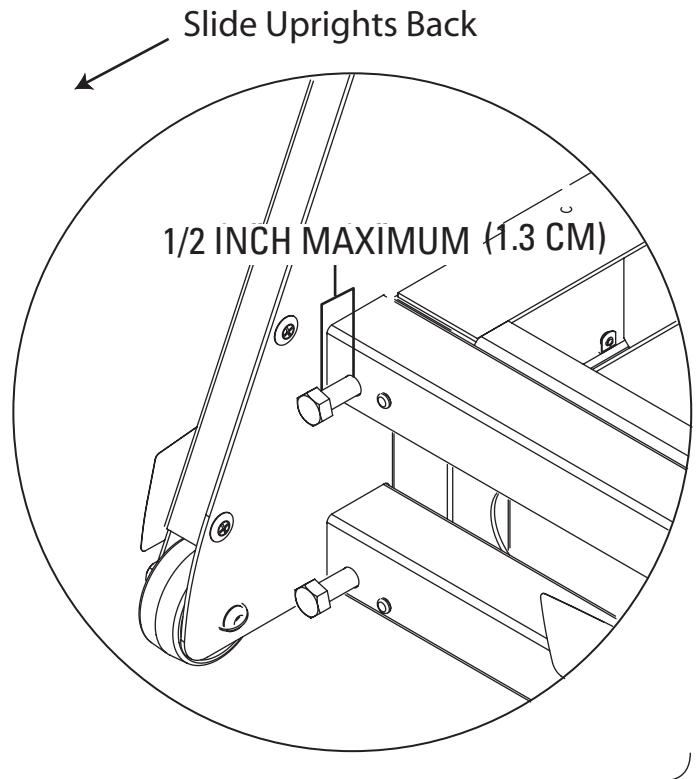
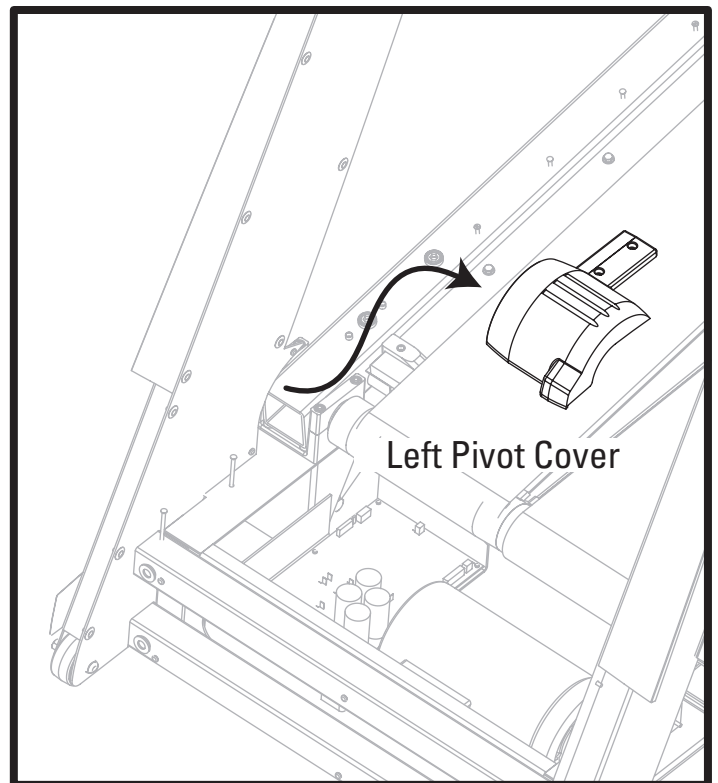

Figure 3



MECHANICAL SERVICE

11.0 - REPLACEMENT OF HYDRAULIC CYLINDERS

Parts Affected:

- Front Cover - P/N 17652
- Left Side Cover - P/N 17656
- Left Lower Pan Cover - P/N 17654
- Left Lower Treadle Cover - P/N 17665
- Left Top Treadle Cover - P/N 17667
- Bolt - P/N 17677
- Cylinder Pivot Weldment - P/N 17586
- Hydraulic Cylinder - P/N SM17810

Tools Needed:

- Phillips screw driver (long & short shaft)
- Loctite 242 (blue)
- 3/8 Allen wrench
- 3/4 inch Socket
- 3/4 inch Open End Wrench
- #15 Torque wrench

To Remove the Hydraulic Cylinder:

BEFORE PERFORMING THE FOLLOWING STEPS MAKE SURE THAT YOU NOTE THE LOCATION AND POSITION OF ALL HARDWARE THAT IS REMOVED.

11-1: Stand on the right treadle to raise the left treadle to full height.

11-2: Turn the power off and unplug the machine from the wall outlet.

See Figure 1 for Steps 3 to 5.

11-3: Remove the Front Cover (P/N - 17652).

11-4: Remove the Left Side Cover (P/N - 17656) and Left Side Pivot Cover.

11-5: Remove the Left Lower Pan Cover (P/N - 17654).

11-6: Unplug two lead wires from cylinder.

11-7: Remove Left Lower Treadle Cover (P/N - 17665).

11-8 Tilt the machine upward slightly and brace with a block of wood under the machine to hold in place.

Figure 1

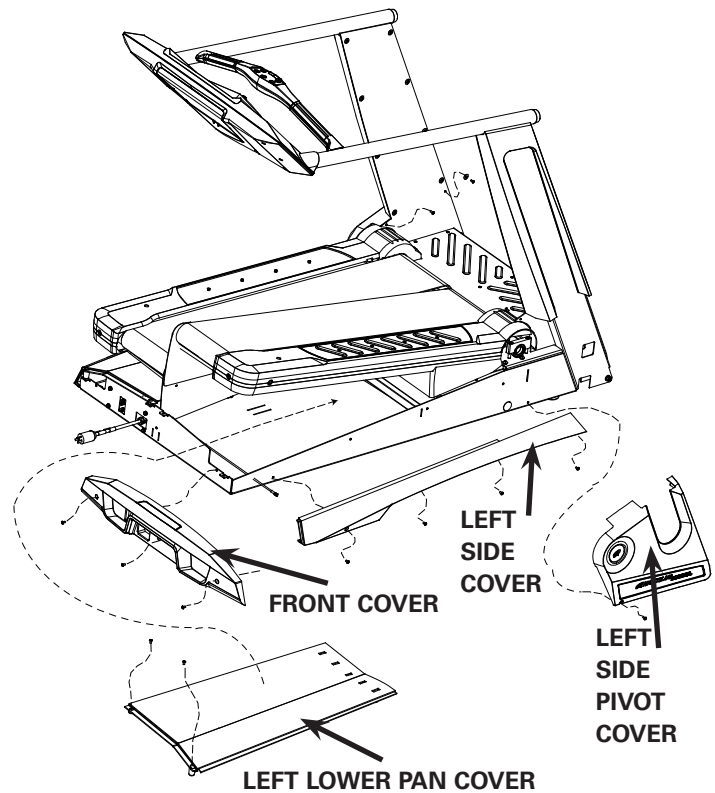

11-9: With a 3/8 inch Allen wrench and 3/4 inch wrench placed on the Nut (P/N - SM22893) under the frame, loosen Bolt (P/N - SM17677) from the Cylinder Mount Weldment (P/N - SM17586) and bracket attachment welded to the base frame.

11-10: Remove the bolt holding the cylinder to the dependency link using a 3/4 inch open-end wrench and 3/4 inch socket (see Figure 2).

11-11: Use a 3/4 inch socket and 3/4 inch open-end wrench to loosen Bolt (P/N - SM26669) from the cylinder mount weldment (see Figure 10-3).

11-12: Remove the two Bolts previously loosened in Step 11-9 and 11-10.

11-13: Remove the hydraulic cylinder. Mark the hydraulic cylinder to show the reason for removing.

To Install the New Hydraulic Cylinder:

11-14: Attach bolt, washers, and nut into the Cylinder Mount Weldment (P/N - SM17867) and new Hydraulic Cylinder (P/N - SM17810), then tighten using a 3/4 inch socket and 3/4 inch Open-end wrench (see Figure 4 - Bolt B).

11-15: Slide new hydraulic cylinder with attached cylinder mount into the bracket attachment welded to the base frame and loosely tighten with Bolt (P/N - SM17677), washer, and Nut (P/N - SM22893). See Figure 4 - Bolt C.

11-16: Attach and tighten the hydraulic cylinder to the dependency link using a 3/4 inch Open-end wrench and 3/4 inch socket with Bolt (P/N - SM25412), washers, and nut (see Figure 4 - Bolt A).

11-17: Return to bolts in Steps 11-1, 11-2 and 11-3 of *Install the New Hydraulic Cylinder* process. Tighten bolts in order of A, C, B (see Figure 4) to 75 Ft Lbs (100 Nm) with a Torque wrench.

11-18: Reconnect the plugs that were disconnected in Step 11-6 of the Removal Process to the hydraulic cylinder.

11-19: Replace the machine covers in reverse order of the Removal Process from Steps 11-7 to 11-3.

Figure 2: Removing the bolt connecting the Hydraulic Cylinder to the Dependency Linkage.

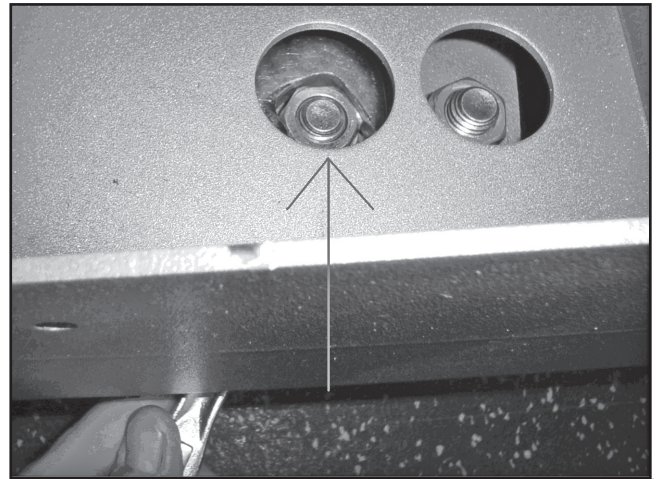

Figure 3: Removing bolt connecting Cylinder Mount Weldment from the Hydraulic Cylinder.

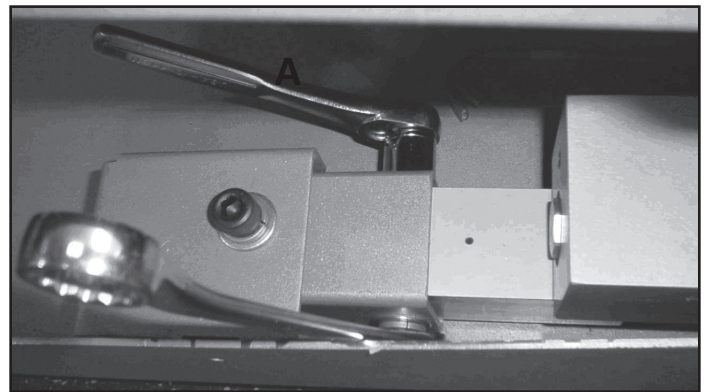
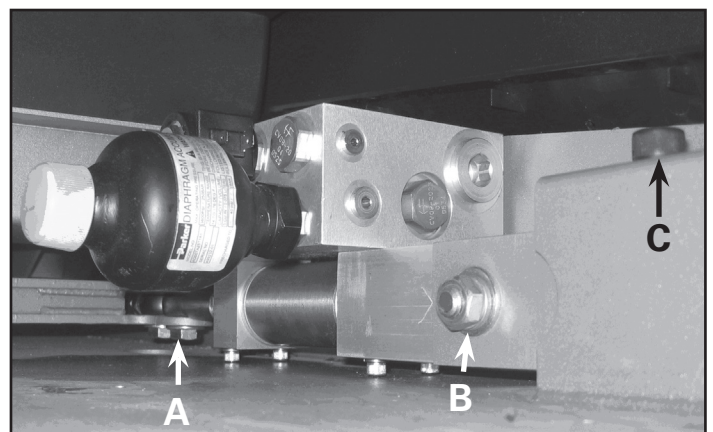

Figure 4: Hydraulic Cylinder bolt locations:



NOTE: All bolts are at 75 ft lbs and should be tightened in A, C, B order always.

12.0 - VIBRATION TROUBLESHOOTING

Parts Affected:

- Rear Step - P/N SM17733
- Step Plate Weldment - P/N SM17591
- Flywheel - P/N SM41059
- Snap Ring - P/N SM17692
- Rear Roller Assembly - P/N SM17501

Tools Needed:

- Phillips screwdriver
- 5/32 Allen bit

To Correct Vibration in treadles:

12-1: Remove the rear step and step plate weldment exposing the rear roller.

Check Flywheel and Motor Mounting:

12-2: Check set screws in flywheel and motor mounting hardware for tightness (see Figure 1).

12-3: Turn machine on and adjust speed to 1 MPH (1.6 km/h).

12-4: Visually inspect the flywheel, if any wobble is noticeable inspect the drive belt on the poly-v pulley and the flywheel for correct alignment. If misalignment is visible move the flywheel and poly-v pulley on the motor into correct alignment position.

NOTE: If the flywheel is replaced and the problem persists the motor may be at fault.

12-5: Try tightening the mounting hardware on the motor a little more before replacing the motor.

Figure 1: Flywheel set screws



Figure 2: Front Roller Snap Ring Location

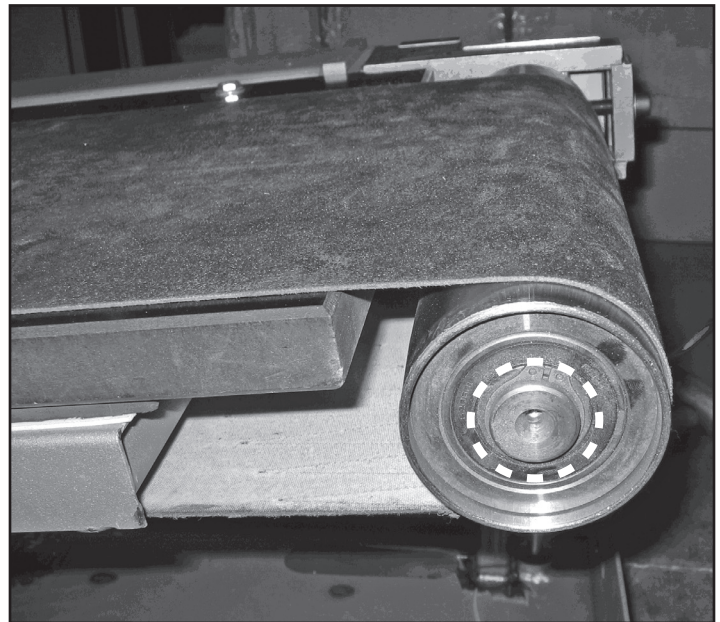

Check the Front Roller Snap Ring:

12-6: Verify that the snap ring on the front rollers is in place properly (see Figure 2).

NOTE: This can be seen more easily with the treadle guards removed.

Check the Rear Roller Pulley:

12-7: Check the rear roller pulley, if the pulley wobbles it was pressed on incorrectly and the entire roller needs to be replaced.

12-8: Check the center of the rear roller (where the two halves join) if there is any wobble the roller was not assembled correctly and needs to be replaced.

CARDIO CONSOLE CODES

General Information:

- Press the UP Speed/Load key [▲], the numeric [#] key, and then press the [ENTER] key once to enter this mode. Pressing [▲] or [▼] forwards or backs up through the selections. Pressing [ENTER] then selects that item. Enter values then press the [ENTER] key again to store the value.
- Once in console codes mode, pressing [▲] [▼] forwards or backs up through the selection, pressing [ENTER] then selects that item. Pressing [CLEAR] exits any of the special access modes.
- Pressing [CLEAR] twice will exit the Console Service Mode.

Workout Default Console Codes:

[▲] [2] [ENTER] "DEFAULTS"

- [▲] [ENTER] "ENTER WT XXX"
- [▲] [ENTER] "ENTER LEVEL 1 TO 20"
- [▲] [ENTER] "ENTER TIME 5 TO 99"
- [▲] [ENTER] "ENTER AGE 10 TO 99"
- [▲] [ENTER] "CHR PERCENT XX"
- [▲] [ENTER] "ENTER SPEED XX.X"
- [▲] [ENTER] "QUICK SPEED XX.X"

NOTE: SEVERAL CODES MAY BE INCLUDED IN THE CONSOLE CODES LIST THAT DO NOT APPLY TO THE TREADCLIMBER® FUNCTIONS.

[▲] [3] [ENTER] "CUSTOMIZE"

- [▲] [ENTER] "MAX TIME"
- [▲] [ENTER] "COOL DOWN"
- [▲] [ENTER] "CHANGE UNITS"
- [▲] [ENTER] "HR INPUTS"
- [▲] [ENTER] "SELECT STATS"
- [▲] [ENTER] "LANGUAGE"
- [▲] [ENTER] "UPPER CONTRAST ADJ"
- [▲] [ENTER] "LOWER CONTRAST ADJ"
- [▲] [ENTER] "MAX SPEED"
- [▲] [ENTER] "ENABLE MAG KEY"
- [▲] [ENTER] "AUTO STOP"
- [▲] [ENTER] "SET DEFAULTS"

[▲] [4] [ENTER] "MACHINE STATUS"

- [▲] [ENTER] " RUN HOURS"
- [▲] [ENTER] " WORKOUTS"
- [▲] [ENTER] " DISTANCE"
- [▲] [ENTER] " CONSOLE VERSION" "Displays Console Version #"
- [▲] [ENTER] "DEVICE TYPE" "Displays Machine Type"
- [▲] [ENTER] " TM DRIVE VER"
- [▲] [ENTER] " MAINT HOURS"

Workout Default Console Codes Continued...

[▲][5][ENTER] " R AND D"

[▲] [ENTER] " PROGRAM LOOP"

[▲] [ENTER] " COM TIMEOUT"

[▲][6][ENTER] " DIAGNOSTIC "

[▲] [ENTER] "DISPLAY TEST"

[▲] [ENTER] "KEY TEST"

[▲] [ENTER] "SERIAL PORTS"

[▲] [ENTER] "A SENSOR B"

[▲] [ENTER] "I/O TEST"

[▲] [ENTER] "BUS VOLTS"

[▲] [ENTER] "TREADLE CENTER"

[▲] [ENTER] "TREADCLIMBER"

[▲][7][ENTER] " MAINTENANCE LOGS "

[▲] [ENTER] "ERROR LOG"

[▲] [ENTER] "MAINT HOURS"

[▲] [ENTER] "QA ID"

[▲][8][ENTER] " CHANGE MACHINE" [ENTER]

For Treadmill Devices, the selections are:

[▲] [ENTER] "TREADCLIMBER"

[▲] [ENTER] "T916"

[▲] [ENTER] "T914"

[▲] [ENTER] "TC/TM CONFIG RQD"

TC9.16 Service Screen Overview

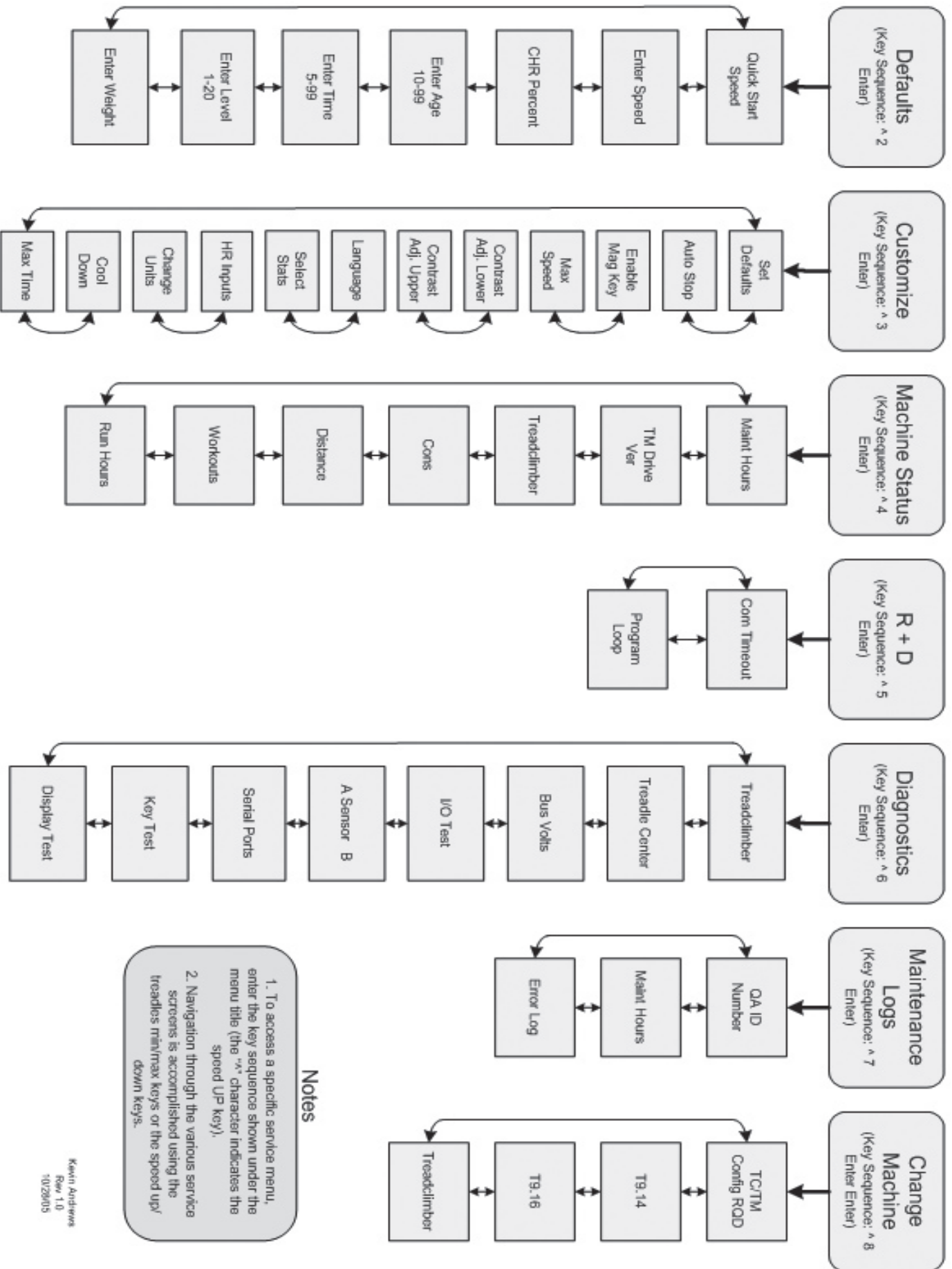

Notes

1. To access a specific service menu, enter the key sequence shown under the menu title (the '^' character indicates the speed UP key).
2. Navigation through the various service screens is accomplished using the treadles min/max keys or the speed up/down keys.

Kevin Andrews
Rev 1.0
10/28/05

ORDERING REPLACEMENT PARTS:

In the US, call 800-628-8458. Outside the US, call +44-26-460-77-77. Authorized Nautilus representatives will assist you with your specific service requirements. Items in the parts list highlighted in gray are replaceable. Items with no warranty code or part number are replaceable as part of a higher-level assembly only.

WARRANTY NOTES (FOR UNITS IN THE USA ONLY):

- 1 - Part covered under standard 3 year parts warranty for replacement.
- 2 - Part covered under standard 1 year wear item warranty for replacement.
- 3 - Part covered under standard 15 year frame and AC-motor warranty.

International warranty coverage may vary. Contact an International office listed in the Important Contact Number section of this manual for information.

REF #:	ASSEMBLY #:	PART #:	DESCRIPTION:	WARRANTY:
	SM17501		ASSEMBLY, REAR ROLLER	3 YEAR
10		SM17568	Weldment, Base Frame	15 YEAR
25		SM17570	Spacer, Treadle Heim Joint	3 YEAR
141		SM17591	Weldment, Rear Step	15 YEAR
26		SM17615	Washer, Shoulder Isolation	3 YEAR
28	SM17617		ASSEMBLY, TREADLE - RIGHT SIDE	
29		SM17508	Assembly, Front Roller	3 YEAR
69		SM17522	Weldment, Right Treadle	15 YEAR
70		SM17526	Weldment, Belt Tensioner	15 YEAR
34		SM17528	Spacer, Rear Bearing	3 YEAR
72		SM17543	Weldment, Cylinder Mount	15 YEAR
106		SM17578	Washer, Lock, Int. Star #10, SS	3 YEAR
255		SM17579	Screw, FH, 10-32 x .75, Hex Dr. SS	3 YEAR
77		SM17608	Weldment, Treadle Guard, Right	15 YEAR
38		SM17609	Casting, Treadle Front Roller Mount	3 YEAR
75		SM17618	Cover, Front Slide	3 YEAR
40		SM17620	Plate, Deck Support	3 YEAR
41		SM17660	Casting, Cover, Right Treadle Pivot	3 YEAR
42		SM17664	Cover, Bottom Treadle Right	1 YEAR
43		SM17666	Cover, Top Treadle Right	1 YEAR
44		SM17673	Block, Treadle End Cap	3 YEAR
242		SM17675	Screw, 1/4-20, x .75, Socket Head Cap	3 YEAR
46		SM17676	Screw, 3/8-24 x 2.00, Socket Head Cap	3 YEAR
47		SM17677	Screw, .500-13 x 4.00, Socket Head Cap	3 YEAR
48		SM17678	Screw, 3/8-24 x 1.50, Socket Head Cap	3 YEAR
68		SM17680	Screw, 3/8-16 1.25, Socket Head Cap	3 YEAR
174		SM17685	Key, 0.190 x 0.190x 1.380	3 YEAR
51		SM17691	Bearing, Ball 30MM x 55MM	3 YEAR
91		SM17692	Snap Ring, External, 25MM Dia.	3 YEAR
73		SM17865	Belt Guide, Aluminum	
55		SM17731	Treadle Step, Right, Insert Molded	1 YEAR

PARTS LIST

REF #:	ASSEMBLY #:	PART #:	DESCRIPTION:	WARRANTY:
98		SM17808	Screw, 10-32 x .375, SHCS, SS	3 YEAR
63		SM17809	Screw, 10-32 x .625, SHCS SS	3 YEAR
173		SM17815	Screw, Button HD Cap, 10-32 x 5 /8L	3 YEAR
68		SM17860	Belt, Treadclimber	1 YEAR
30		SM17862	Deck, Treadle	1 YEAR
228		SM22047	Washer, Flat 1/4 ID x 5/8 OD	3 YEAR
90		SM22098	Screw, .250-20 x 1.50, Hex Head Cap	3 YEAR
58		SM22276	Screw, #6 S.T. x .625 Hex OR TO	3 YEAR
254		SM25777	Screw, .250-20 x 1.00 Button Head	3 YEAR
88		SM27585	Washer, .406 x .812 x .065 Flat	3 YEAR
65	SM17623		ASSEMBLY, TREADLE LEFT	3 YEAR
29		SM17508	Assembly, Front Roller	3 YEAR
32		SM17523	Weldment, Left Treadle	15 YEAR
70		SM17526	Weldment, Belt Tensioner	15 YEAR
34		SM17528	Spacer, Rear Bearing	3 YEAR
72		SM17543	Weldment, Cylinder Mount	15 YEAR
106		SM17578	Washer, Lock, Int. Star #10, SS	3 YEAR
255		SM17579	Screw, FH, 10-32 x .75, Hex Dr. SS	3 YEAR
38		SM17609	Casting, Treadle Front Roller Mount	3 YEAR
75		SM17618	Cover, Front Slide	3 YEAR
40		SM17620	Plate, Deck Support	3 YEAR
37		SM17625	Weldment, Left Treadle Guard	15 YEAR
78		SM17661	Casting, Cover, Left Treadle Pivot	3 YEAR
79		SM17665	Cover, Bottom Treadle Left	1 YEAR
80		SM17667	Cover, Top Treadle Left	1 YEAR
44		SM17673	Block, Treadle End Cap	3 YEAR
242		SM17675	Screw, 1/4-20, x .75, Socket Head Cap	3 YEAR
46		SM17676	Screw, 3/8-24 x 2.00, Socket Head Cap	3 YEAR
47		SM17677	Screw, .500-13 x 4.00, Socket Head Cap	3 YEAR
48		SM17678	Screw, 3/8-24 x 1.50, Socket Head Cap	3 YEAR
68		SM17680	Screw, 3/8-16 1.25, Socket Head Cap	3 YEAR
73		SM17685	Guide, Belt	3 YEAR
51		SM17691	Bearing, Ball 30MM x 55MM	3 YEAR
91		SM17692	Snap Ring, External, 25MM Dia.	3 YEAR
101		SM17732	Treadle Step, Left, Insert Molded	1 YEAR
98		SM17808	Screw, 10-32 x .375, SHCS, SS	3 YEAR
63		SM17809	Screw, 10-32 x .625, SHCS SS	3 YEAR
173		SM17815	Screw, Button HD Cap, 10-32 x 5 /8L	3 YEAR
68		SM17860	Belt, Treadclimber	1 YEAR
30		SM17862	Deck, Treadle	1 YEAR
228		SM22047	Washer, Flat 1/4 ID x 5/8 OD	3 YEAR
90		SM22098	Screw, .250-20 x 1.50, Hex Head Cap	3 YEAR

PARTS LIST

REF #:	ASSEMBLY #:	PART #:	DESCRIPTION:	WARRANTY:
58		SM22276	Screw, #6 S.T. x .625 Hex OR TO	3 YEAR
254		SM25777	Screw, .250-20 x 1.00 Button Head	3 YEAR
88		SM27585	Washer, .406 x .812 x .065 Flat	3 YEAR
	SM17626		ASSEMBLY, UPRIGHT	
110		SM17702	Housing, Ergo, CHR, Top Left	1 YEAR
111		SM17703	Housing, Ergo, Bottom Left	1 YEAR
112		SM17704	Housing, Ergo, CHR, Top Right	1 YEAR
113		SM17705	Housing, Ergo, Bottom Right	1 YEAR
114		SM17739	Keypanel, Ergo, TC916	1 YEAR
256		SM40639	Screw, 6-32 x .438 Lg Shc	3 YEAR
121		SM41034	Contact Plate, CHR	1 YEAR
122		SM41112	Housing, Ergo, Bottom Center	1 YEAR
123		SM41158	End Cap, Handle Barm Molded	1 YEAR
		SM41169	Cable Harness	3 YEAR
		SM41180	Heart Rate Detection Module	3 YEAR
		SM41193	Cable Harness	3 YEAR
257		SM41268	Screw, 6-32 x .3125, SHCS	3 YEAR
		SM41443	Cable Harness	3 YEAR
102		SM17793	Assy, Weldment, Upper Right	
252		SM17794	Assy, Weldment, Lower Right	
N/A		SM17824	Assy, Harness Extension, Console	
N/A		SM17826	Assy, Harness, Extension, VSD	
N/A		SM17775-007	Intrnl/Extrnl Washer .375	
N/A		SM25796	Screw, .375-16 x 1.00, BH, SS	
		SM41449	Assy, Ergo Bar, Touch Sensor	1 YEAR
27		SM17631	Belt, Drive, Poly-V	3 YEAR
	SM17640		ASSEMBLY, TREADLE DEPENDENCY	
129		SM17551	Weldment, Treadle Rocker	15 YEAR
135		SM41048	Bearing, Ball, 25MM x 52MM	3 YEAR
130		SM17639	Shaft, Rocker Pivot	3 YEAR
52		SM17692	Snap Ring, External, 25MM Dia	3 YEAR
128		SM17548	Gear, 120T (48DP), Cut	3 YEAR
251		SM17742	Bracket, Gear Locking	3 YEAR
250		SM24088	Washer, #10 Split Lock	3 YEAR
136	SM17641		ASSEMBLY, DEPENDENCY LINK	
146		SM17651	Bumper, Rubber Stop	3 YEAR
147		SM17652	Cover, Front Trim	1 YEAR
148		SM17653	Cover, Right Pan	1 YEAR
149		SM17654	Cover, Left Pan	1 YEAR
150		SM17655	Cover, Right Side	1 YEAR
151		SM17656	Cover, Left Side	1 YEAR
152		SM17657	Cover, Right Pivot	1 YEAR

PARTS LIST

REF #:	ASSEMBLY #:	PART #:	DESCRIPTION:	WARRANTY:
153		SM17658	Cover, Left Pivot	1 YEAR
154		SM17659	Cover, Lower Front Step	1 YEAR
107		SM17668	Cover, Top Upright Right	1 YEAR
108		SM17669	Cover, Top Upright Left	1 YEAR
155	SM17670		ASSEMBLY, CONSOLE TC916	3 YEAR
46		SM17676	Screw, 3/8-24 x 2.00, SHC	3 YEAR
177		SM17682	Screw, 3/8-16 x 1.00 Button Head Cap	3 YEAR
172		SM17683	Screw, .500-13 x 3.25, Hex Head Cap	3 YEAR
175		SM17686	Leveler, 0.500 inches-13 x 0.875 Tall	3 YEAR
178	SM17688		ASSMEBLY, VSD, TC9.16	3 YEAR
260 - INT	SM41404		Assembly, Choke, 6MH, International Units	
253		SM17689	Decal, Step Warning	1 YEAR
258		SM17695	Screw, #10-32 x 0.375, Flat Head, Phil	3 YEAR
188	SM17719		ASSEMBLY, CONFIG PLATE, TC9 SERIES (USA Domestic Units)	3 YEAR
188 - INT	SM17823		Assembly, Config Plate, 230V, International Units TC9	
63		SM28214	Screw, 10-32 x .750 Socket HDCP	
125		SM17569	Assy., Treadle Mount	
143		SM17733	Rear Step, Insert Molded	1 YEAR
63		SM17809	Screw, 10-32 x .625, SHCS, SS	3 YEAR
126	SM17810		ASSMEBLY, CYLINDER, HYD. CONTROL, TC916	
173		SM17815	Screw, Button Hd Cap, 10-32 x 5/8L	3 YEAR
233		SM22030	Washer, 3/8 USS Flat	3 YEAR
228		SM22047	Washer, Flat 1/4 ID x 5/8 OD	3 YEAR
132		SM22091	Washer, .50 SAE Flat	3 YEAR
133		SM22222	Washer, Split Lock, .50	3 YEAR
138		SM22893	Nut, Jam, .500-13 UNC, Grade 8	3 YEAR
230		SM24643	Nut, .375-16, HX Jam, Nylon Insert	3 YEAR
237		SM27487	Drive Motor, AC Variable	15 YEAR
238		SM27562	Washer, Neoprene, .490x1.063x.09	3 YEAR
239		SM27577	Screw, M6 x 1.00 x 16 HHCAP	3 YEAR
240		SM27578	Washer, M6, Splitlock, Zinc	3 YEAR
241		SM27579	Washer, M6, Flat, Zinc	3 YEAR
226		SM27586	Spacer, Nylon, .125x .500 x 1.120	3 YEAR
	SM40837		Assembly, Rotary Encoder	3 YEAR
8		SM41059	Flywheel, Cast, NTR 6000/7000	3 YEAR
9		SM17545	Assembly, Position Sensor TC	
134		SM25412	Screw, .500-13 x 1.75 Hex HD CA	
212		SM17737	Decal, Siderail, Right	
210		SM17740	Decal, Rear Pivot	
209		SM17736	Decal, Rear Hood	
211		SM17738	Decal, Siderail, Left	

WORKING WITH EXPLODED VIEWS

The reference numbers in the drawings on the following pages correlate to the reference numbers in the parts list on the preceding pages.

Base Frame with Drive Motor:

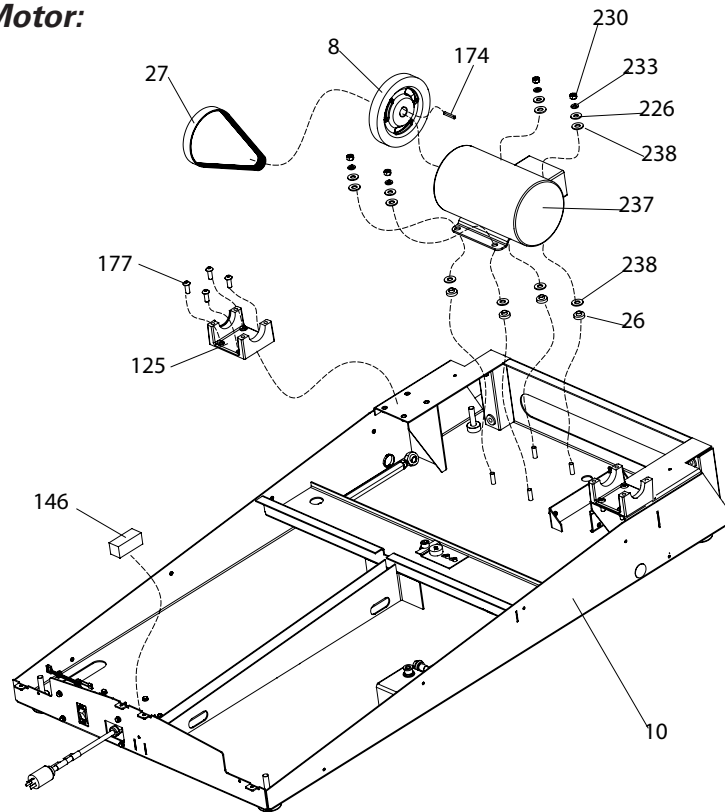

Base Frame with VSD Motor Control Board:

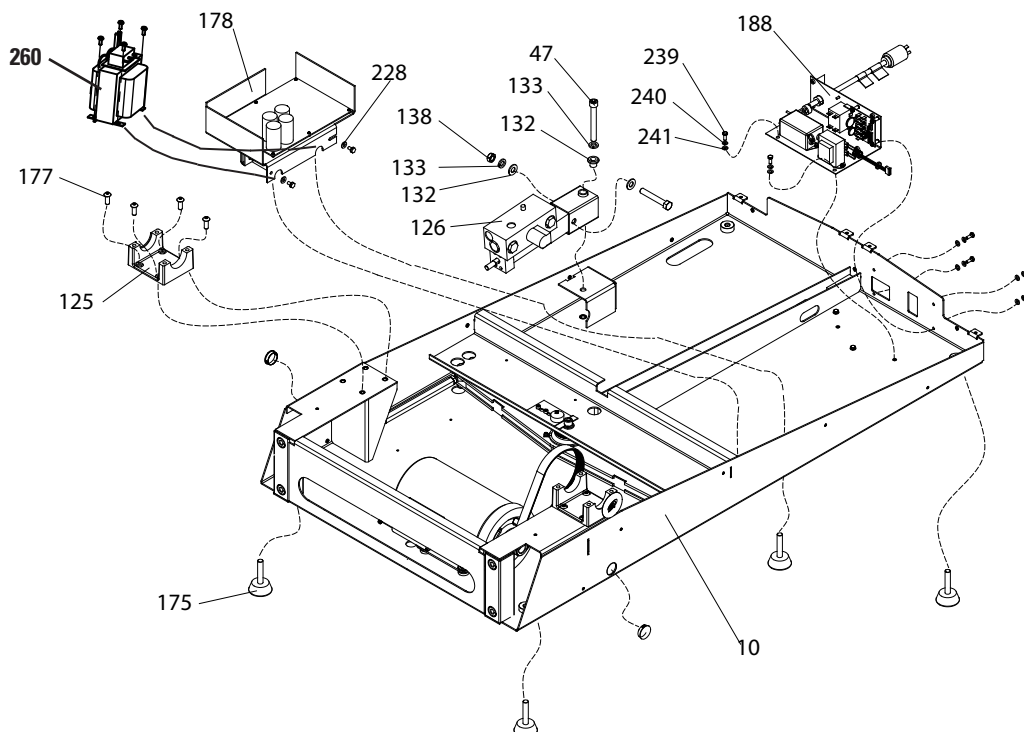

EXPLODED VIEWS

Base Frame with Dependency Link and Hydraulic System:

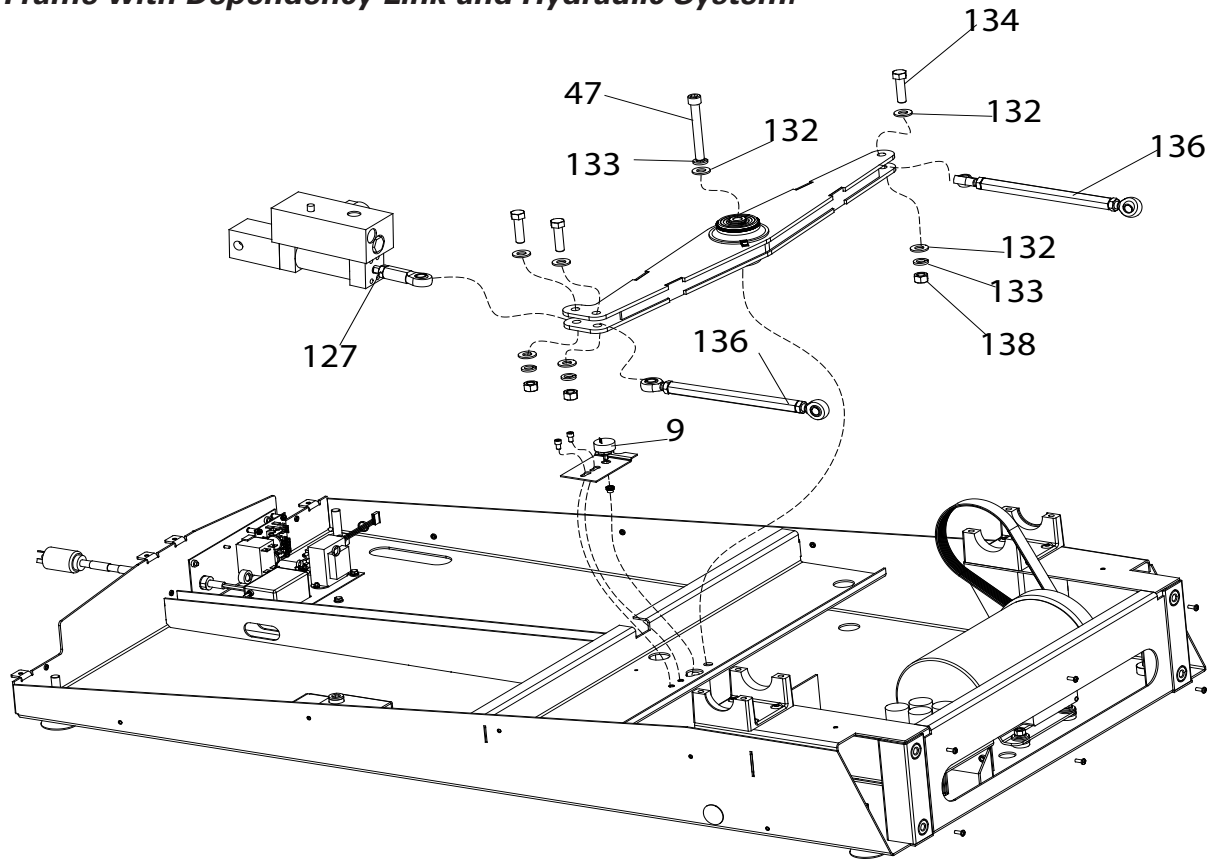

Dependency Link:

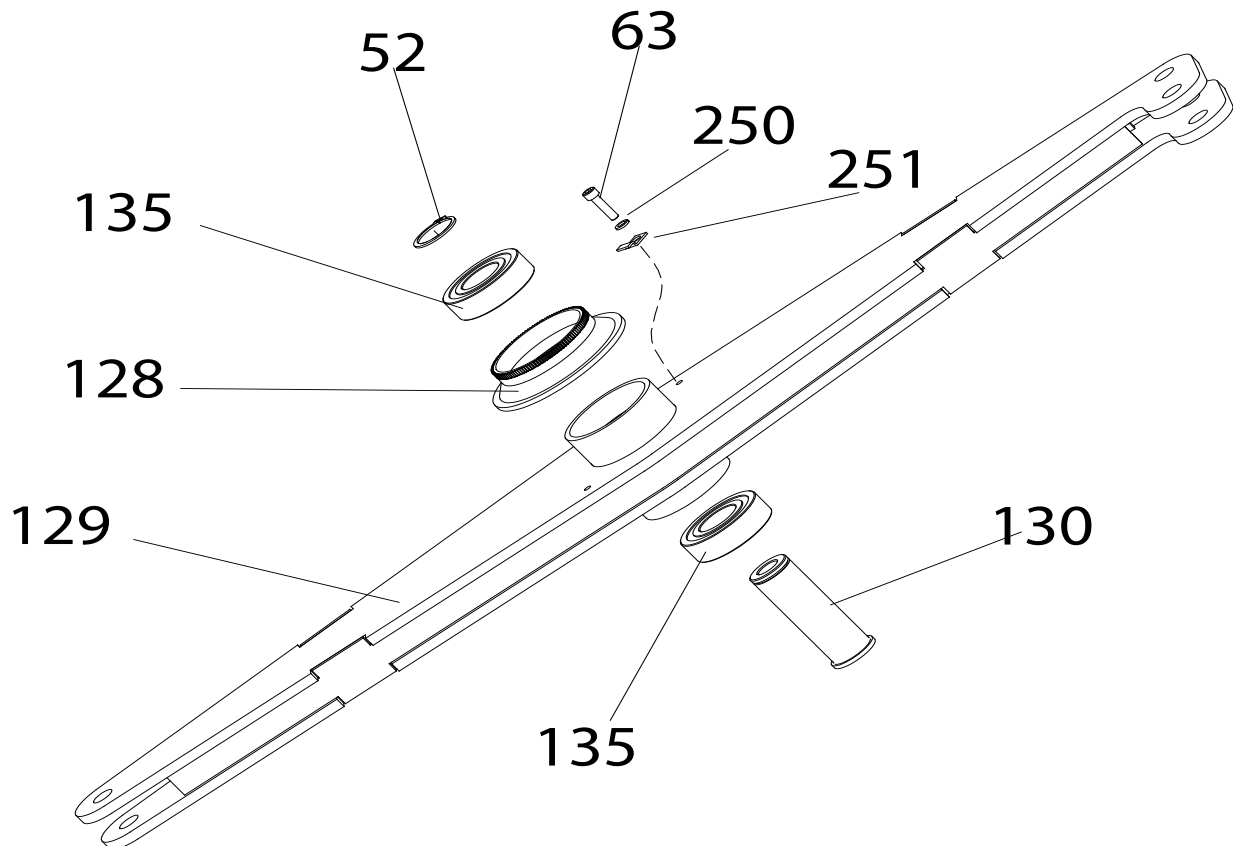

Treadle Assembly:

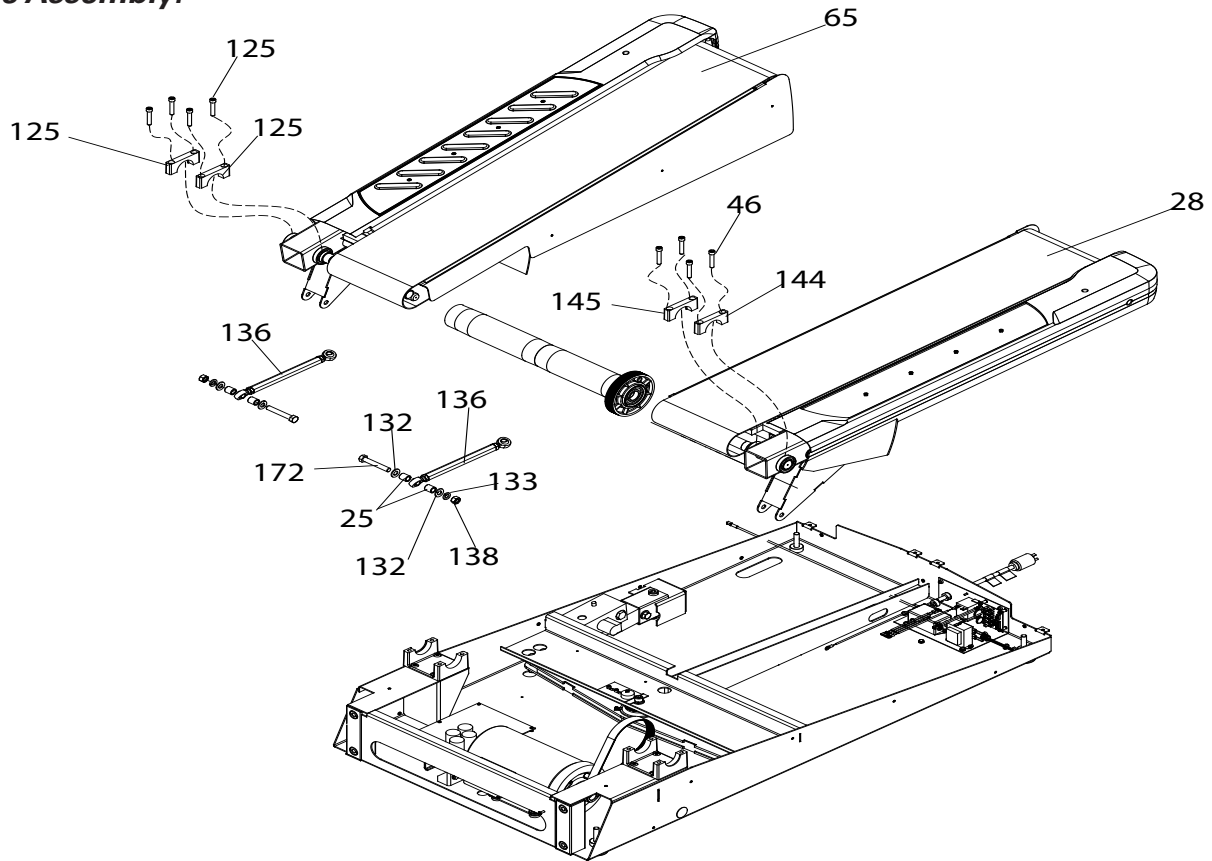

Console Upright Assembly, Rear Step and Console Assembly:

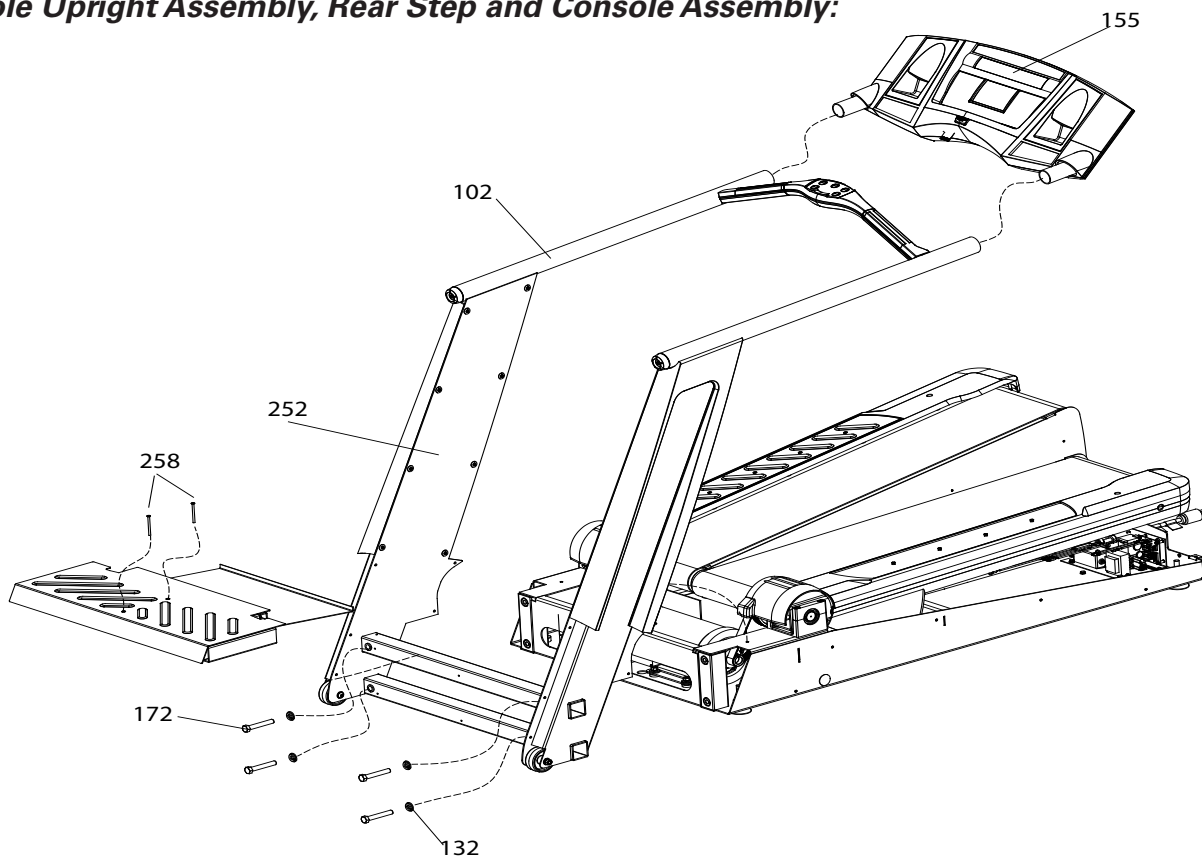

EXPLODED VIEWS

Base Frame Covers: (Right side as you stand on unit facing console.)

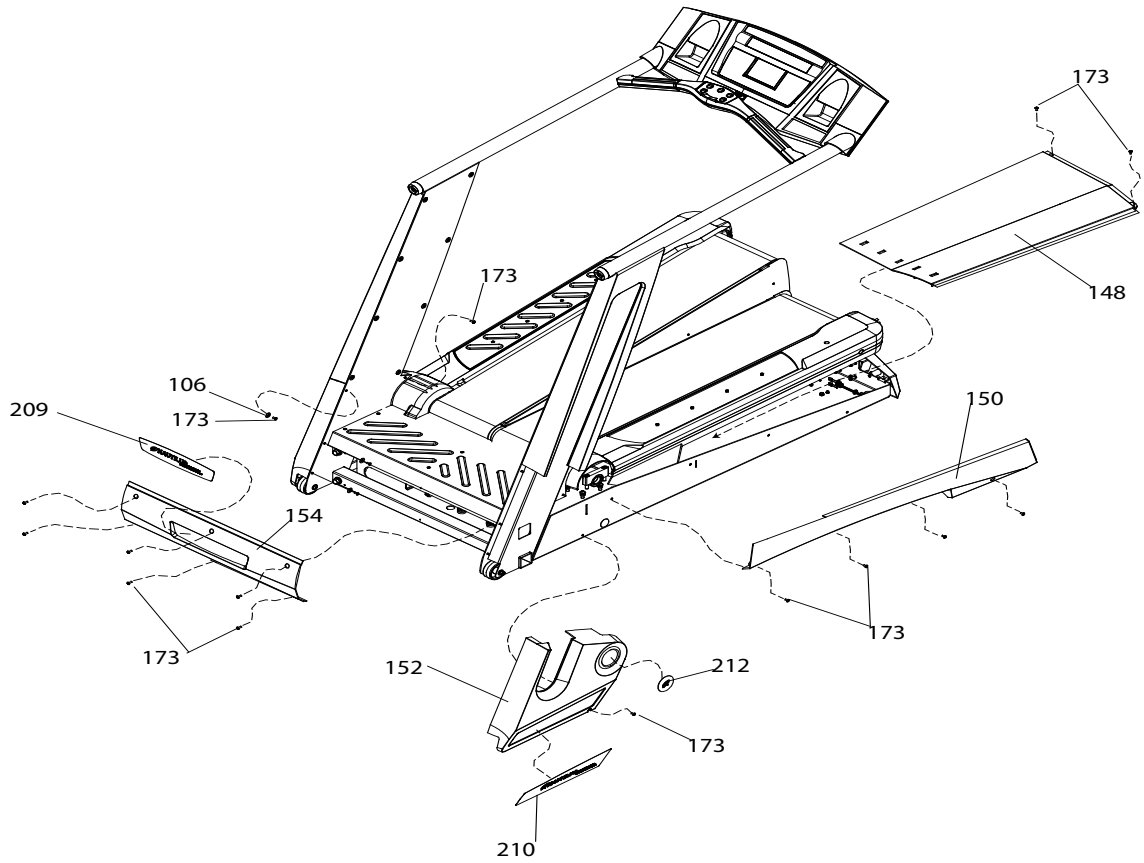

Base Frame Covers: (Left side as you stand on unit facing console.)

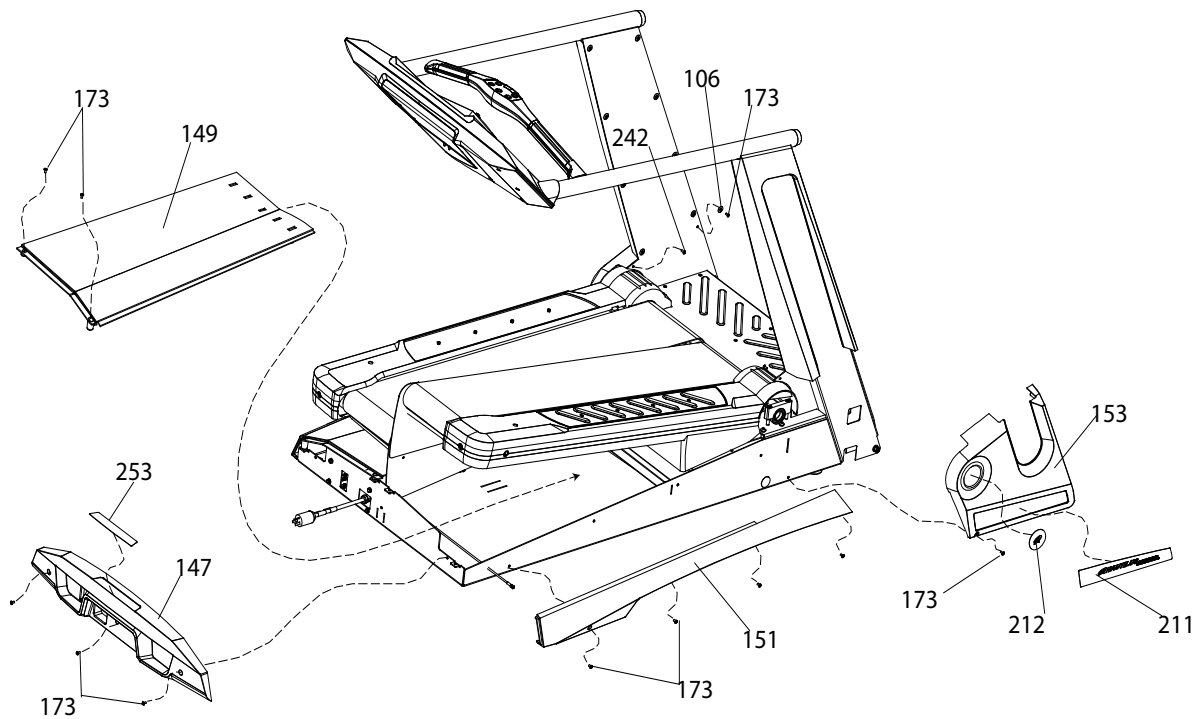

Treadle Deck and Belt Assembly: (Right side as you stand on unit facing console.)

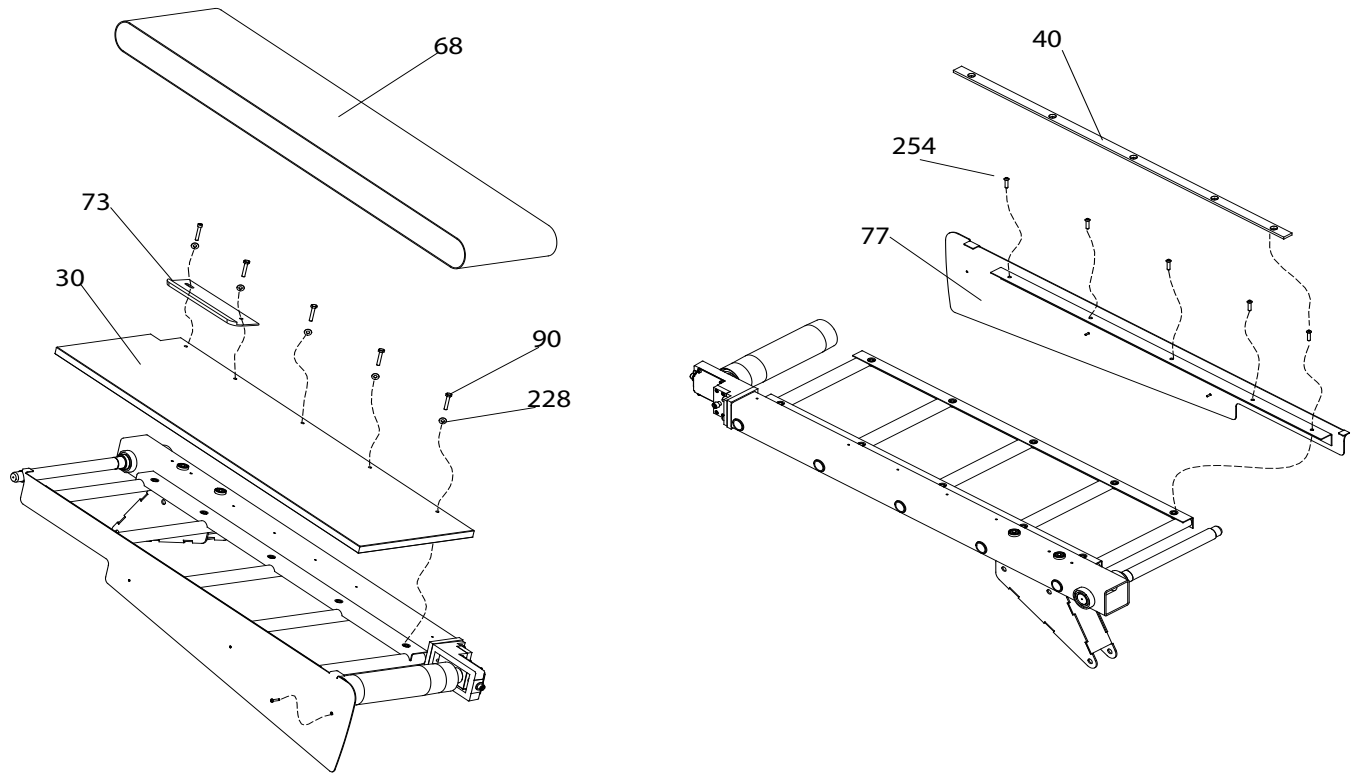

Treadle Deck and Belt Assembly: (Left side as you stand on unit facing console.)

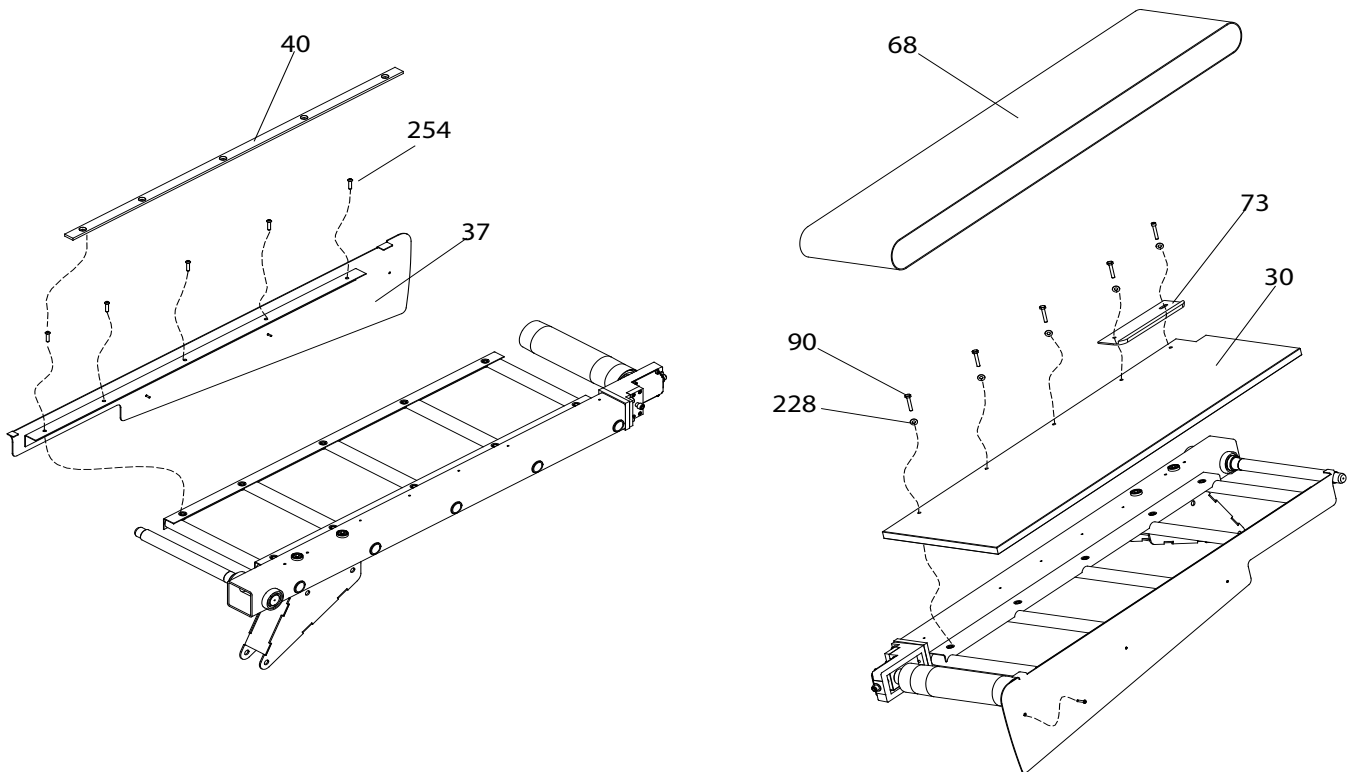

EXPLODED VIEWS

Treadle Arm Assembly: (Right side as you stand on unit facing console.)

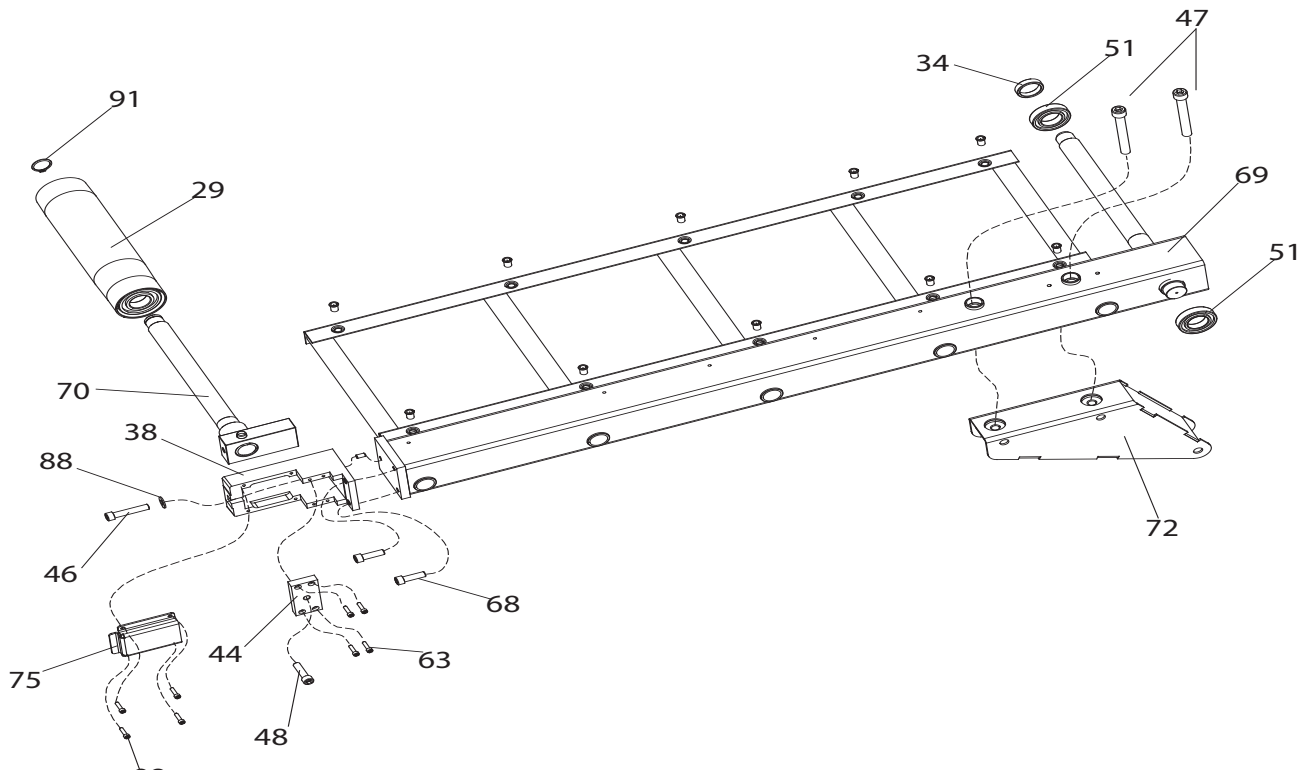

Treadle Arm Assembly: (Left side as you stand on unit facing console.)

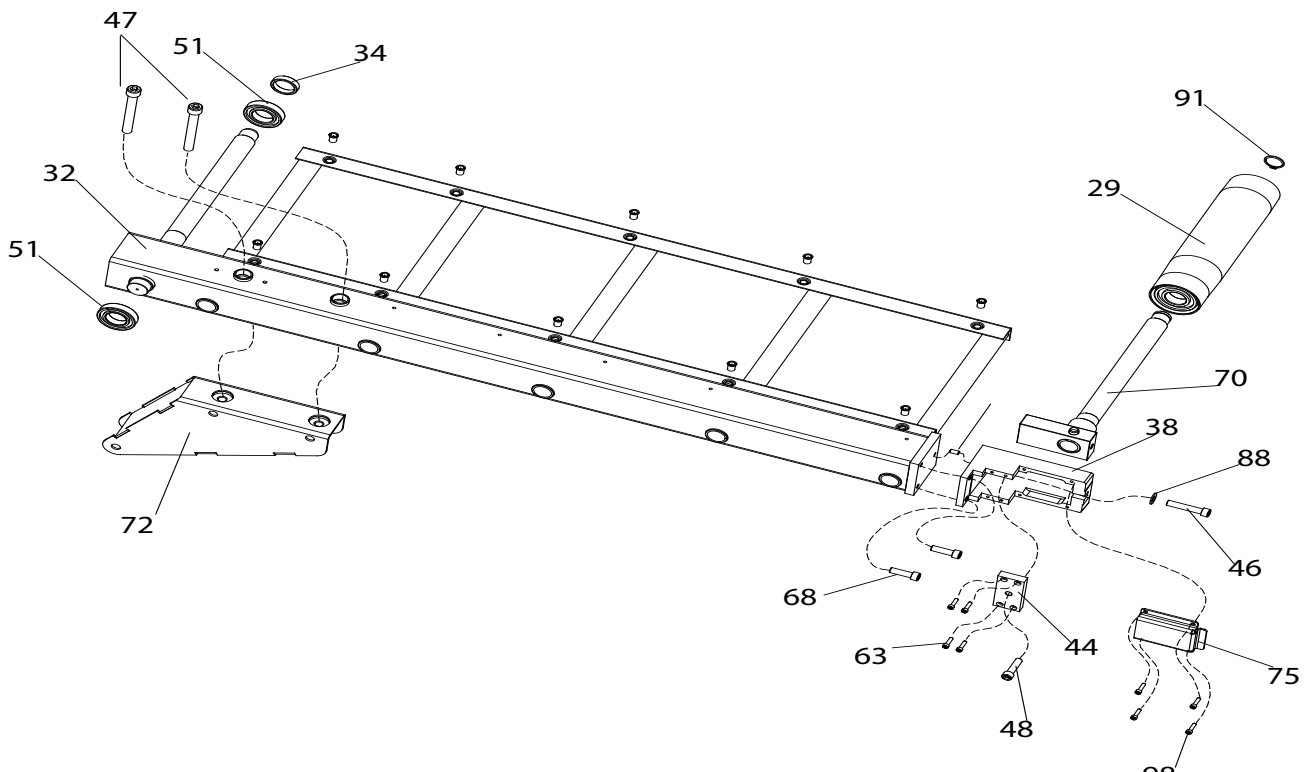

Treadle Covers - Top and Bottom: (Right side as you stand on unit facing console.)

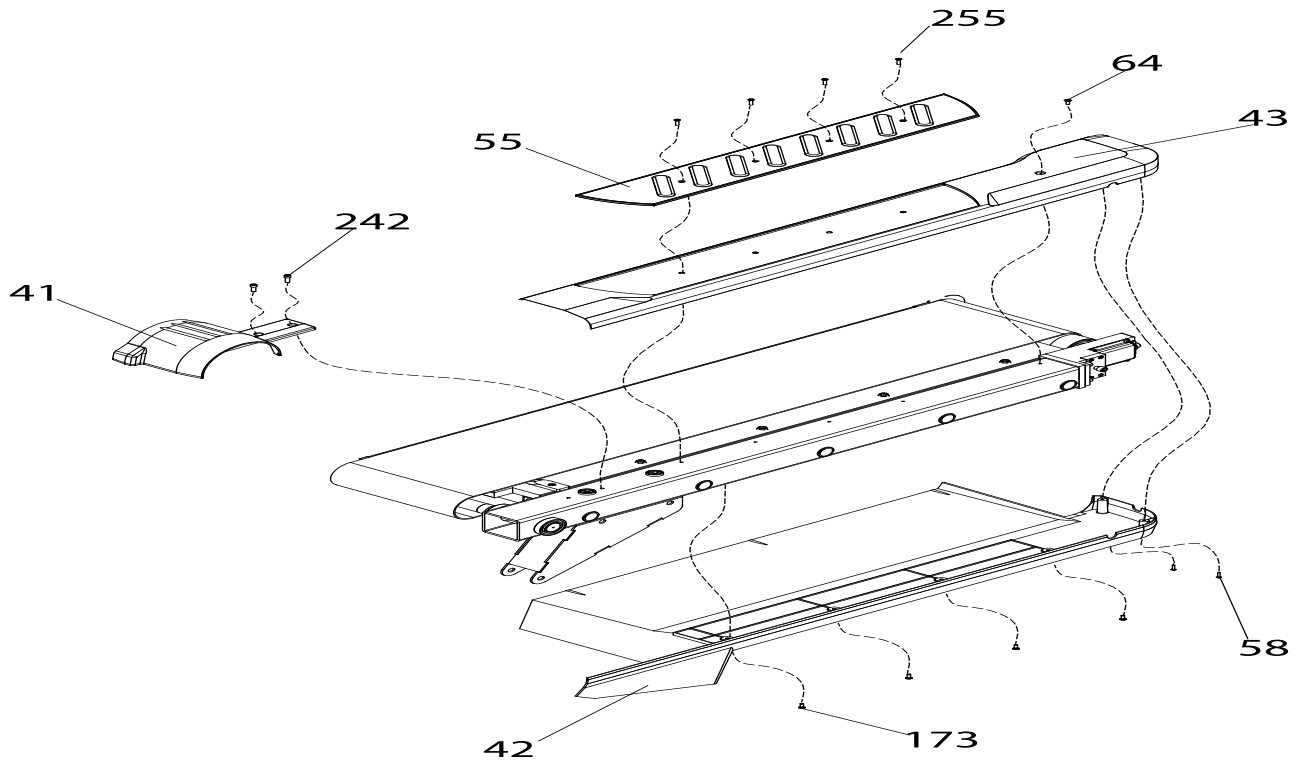

Treadle Covers - Top and Bottom: (Left side as you stand on unit facing console.)

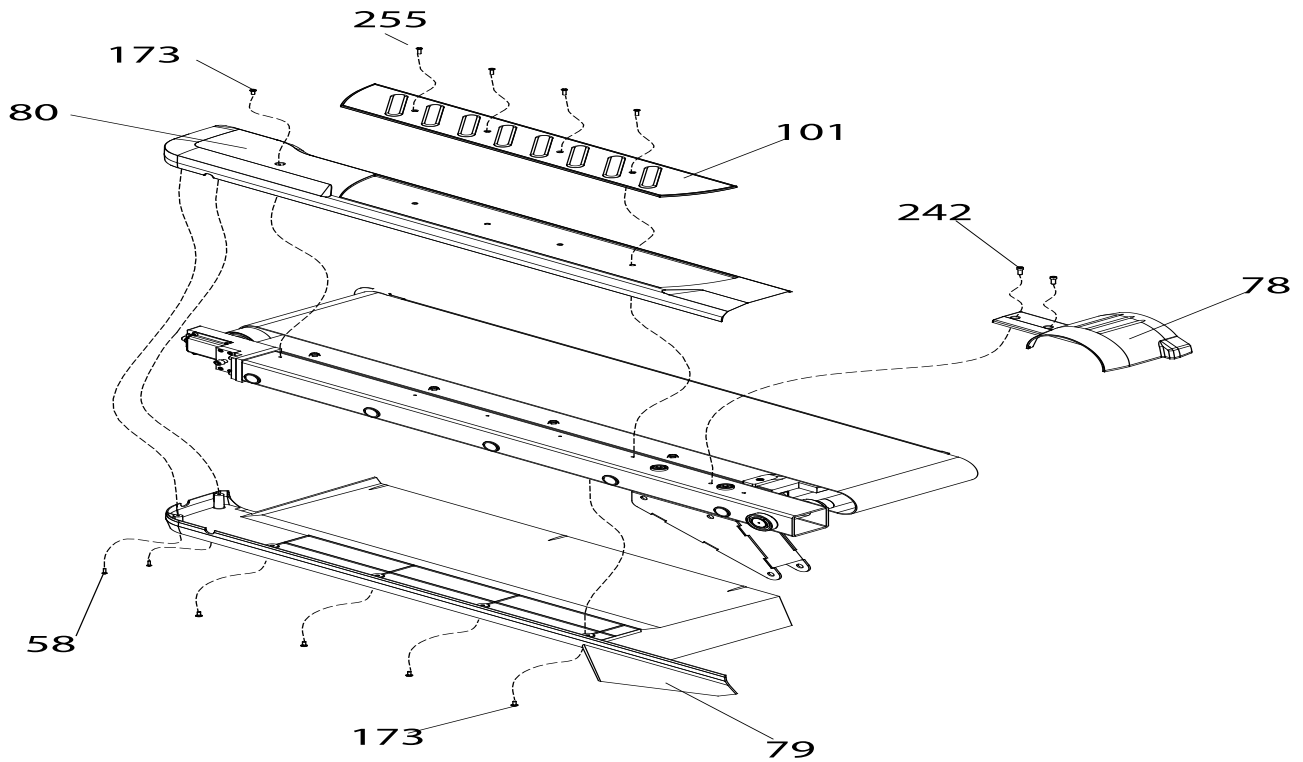

EXPLODED VIEWS

ROC Bar Assembly:

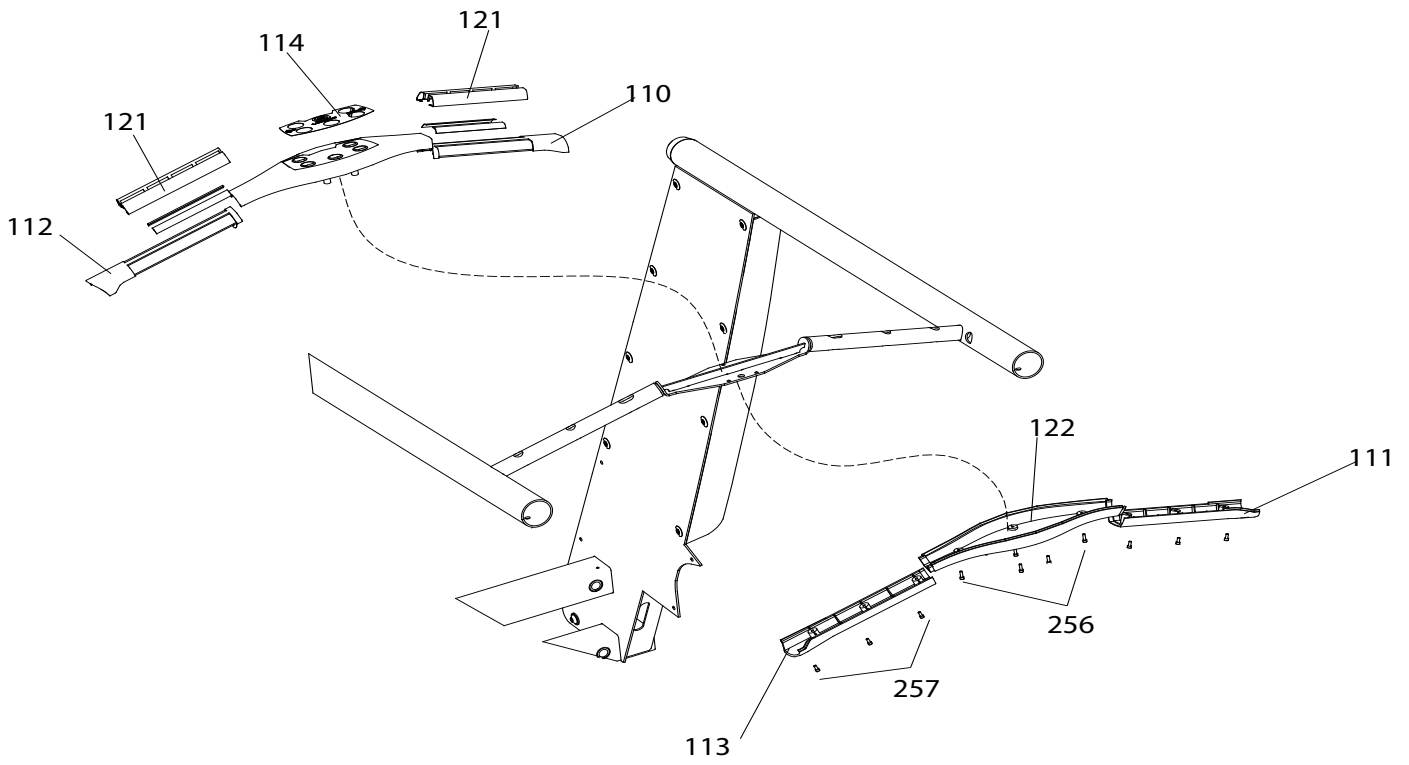

Console Upright and Cover Assembly:

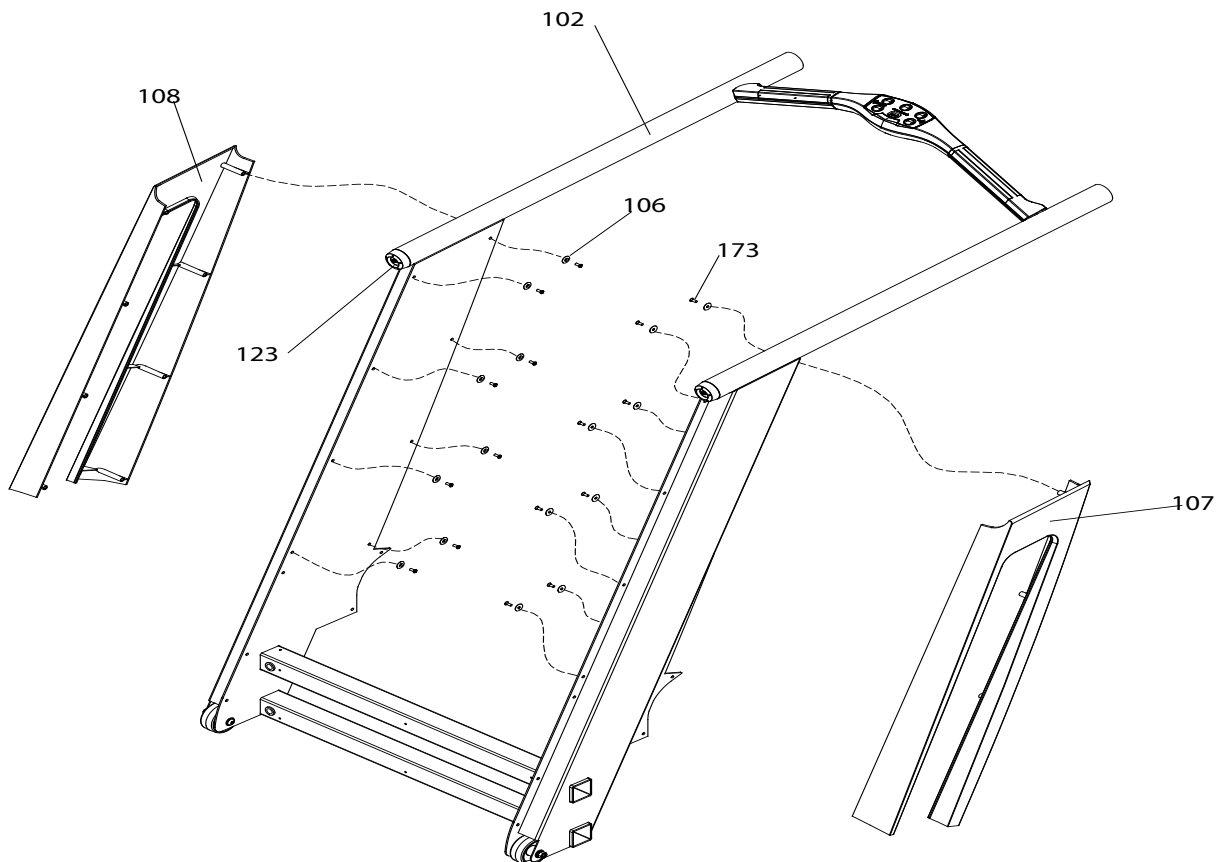

Rear Step and Support Platform:

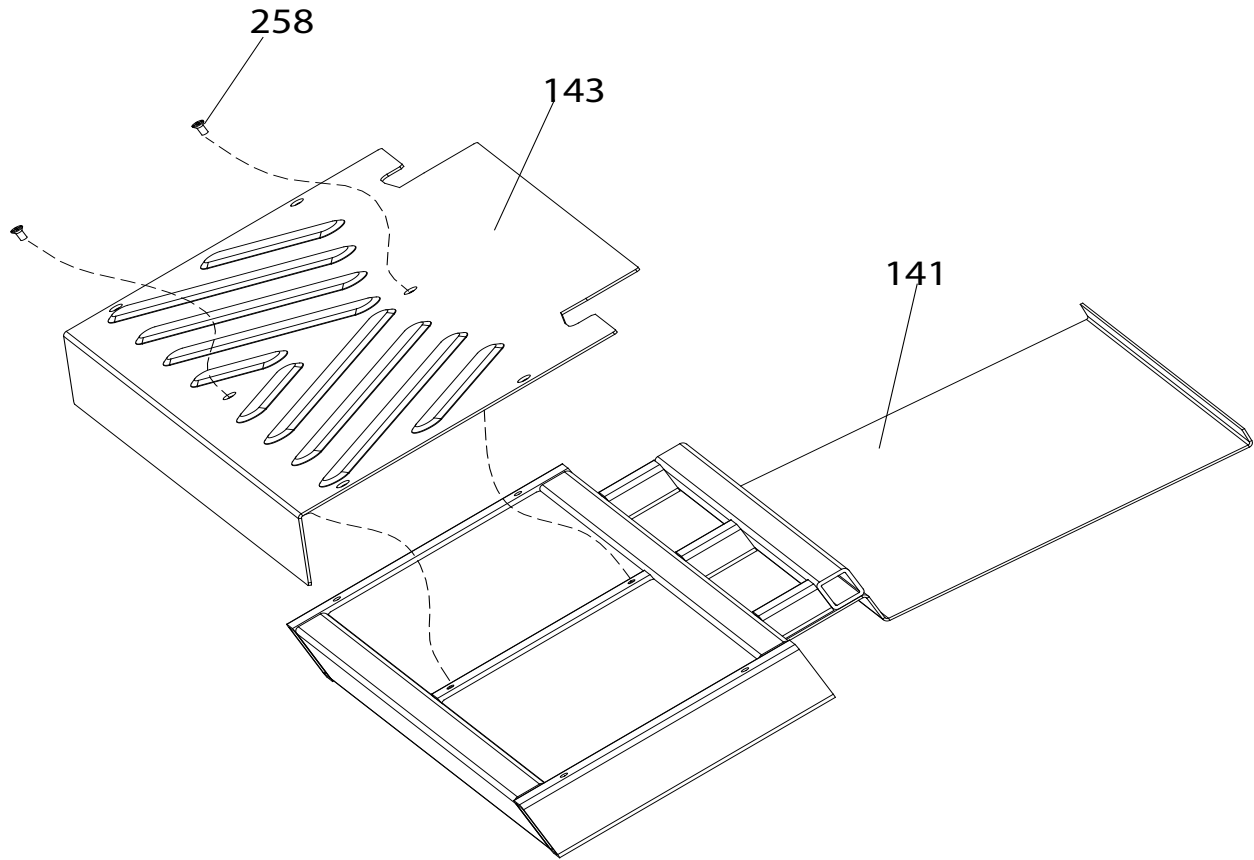

ELECTRONIC TROUBLESHOOTING SUMMARY

1. LED Operation on PCBAs	What this means	First Action	Second Action	Third Action	Fourth Action
Note about use of Status LEDs: A single LED does not show the complete picture of an error condition. Review the status of all LEDs prior to deciding which assemblies to replace.					
P51 Processor PCBA:					
DS1 Flashing @ 1 Second Rate	Normal Condition.	Normal condition, no action required.			
DS1 Flashing @ Irregular Rate	P51 Processor PCBA Non-operational.	Power off/on treadmill, see if problem self-clears. Check for unplugged or damaged cables. Communication cable from J10 on P51 Processor PCBA is cable most likely to cause problem.	Replace P51 Processor PCBA.		
DS1 Off	Processor is non-operational. No power or P51 Processor PCBA has failed.	Power off/on treadmill, see if problem self-clears. Check for unplugged or damaged cables. Communication cable from J10 on P51 Processor PCBA is cable most likely to cause problem.	Check LEDs on VSD to see if VSD has power.	Replace P51 Processor PCBA.	
DS1 On Continuous	P51 Processor PCBA Non-operational.	Power off/on treadmill, see if problem self-clears.	Replace P51 Processor PCBA.		
VSD PCBA:					
DS1 Flashing @ Any Rate	VSD PCBA is Non-operational.	Power off/on treadmill, see if problem self-clears. Check for unplugged or damaged cables. Communication cable from J10 on P51 Processor PCBA is cable most likely to cause problem.	Replace VSD PCBA.		
DS1 Off	Walkbelt motor is OFF.	Normal condition, no action required.			
DS1 On Continuous	Walkbelt motor is ON.	Normal condition, no action required.			
DS2 Flashing @ 1 Second Rate	Normal condition.	Normal condition, no action required.			
DS2 Flashing @ Irregular Rate	Processor in reset is attempting to re-establish communication.	Power off/on treadmill, see if problem self-clears. Check for unplugged or damaged cables. Communication cable from J10 on P51 Processor PCBA is cable most likely to cause problem.	Replace VSD PCBA.	Replace Configuration Plate.	
DS2 Off	Processor in reset or no communication.	Power off/on treadmill, see if problem self-clears. Check for unplugged or damaged cables. Communication cable from J10 on P51 Processor PCBA is cable most likely to cause problem.	Replace VSD PCBA.	Replace P51 Processor PCBA.	Replace Configuration Plate.

ELECTRONIC TROUBLESHOOTING SUMMARY

1. LED Operation on PCBAs	What this means	First Action	Second Action	Third Action	Fourth Action
DS2 On Continuous	Walkbelt Over current Condition.	This error is usually caused by excessive drag or friction on the deck. Closely inspect the deck and look for signs of excessive wear. If needed replace the belt and deck.	Power off/on treadmill, see if problem self-clears. Check for unplugged or damaged cables.	Replace VSD PCBA.	Replace Drive Motor.
DS3 On Continuous	5V VCC Power Supply is Operational.	Normal condition, no action required.			
DS3 Off	5V VCC Power Supply is Non-operational.	Check for unplugged or damaged cables. Cable going to P14 on VSD PCBA is most likely to cause problem.	Use an ohmmeter to verify Config PCBA fuses F3 and F4.	Replace VSD PCBA.	Replace Configuration Plate.
DS4 On Continuous	15V Predrive Power Supply is Operational.	Normal condition, no action required.			
DS4 Off	15V Predrive Power Supply is Non-operational.	Check for unplugged or damaged cables. Cable going to P20 on VSD PCBA is most likely to cause problem.	Use an ohmmeter to verify Config PCBA fuses F3 and F4.	Replace VSD PCBA.	Replace Configuration Plate.
DS5 On Very Bright	Danger! High Voltage Drive Bus Voltage Present.	Normal powered up condition. Do not handle VSD PCBA until LEDs go out after about 2 minutes.			
DS5 Off	High Voltage Drive Bus Capacitors have Discharged.	High Voltage Drive Bus is discharged and VSD PCBA is safe to handle.			
DS6 On Very Bright	Danger! High Voltage Drive Bus Voltage Present.	Normal powered up condition. Do not handle VSD PCBA until LEDs go out after about 2 minutes.			
DS6 Off	High Voltage Drive Bus Capacitors have Discharged.	High Voltage Drive Bus is discharged and VSD PCBA is safe to handle.			
2. Self-Test Error Codes	What this means	First Action	Second Action	Third Action	Fourth Action
ALU Error Program Error Static RAM Error Timer Error	Internally generated processor error.	Power off/on treadmill, see if problem self-clears.	Replace P51 Processor PCBA.		
EEPROM Error	Stored data such as user preferences, total time, and mileage has been corrupted.	Power off/on treadmill, see if problem self-clears. Defaults and configuration data will need to be entered again.	Replace P51 Processor PCBA.		

ELECTRONIC TROUBLESHOOTING SUMMARY

3. Operational Error Codes	What this means	First Action	Second Action	Third Action	Fourth Action
DRIVE ERROR	Occurs when the VSD PCBA detects too low or too high of a voltage on the DC drive bus.	Verify input line voltage is within specifications. Error indicates voltage is too low or high.	Ensure all cables from the configuration plate to the VSD PCBA are connected. Cable going to P20 on VSD PCBA is most likely to cause problem.	Replace VSD PCBA.	Replace Configuration Plate.
DRIVE PWR ERROR Early versions of software displayed this error as "ABS ERROR" or "POWER LOSS ERROR"	Can occur during program operation. Treadmill goes to idle and stops quickly. This Error can denote any of the following: 1 - The DC bus that powers the walkbelt is too low or high. 2 - The thermal switch on the walkbelt motor is open due to the motor overheating. 3 - The circuitry that measures the walkbelt motor current has failed.	Verify input line voltage is within specifications. Error indicates voltage is too low or high.	Let walkbelt motor cool down and cycle power. Motor thermal switch may open due to worn belt and deck.	Ensure all cables from the configuration plate to the VSD PCBA are connected. Cable going to P20 on VSD PCBA is most likely to cause problem.	Replace VSD PCBA. If problem persists replace Configuration Plate.
DRV RESET	The processor on the VSD PCBA cannot communicate with the motor control IC on the VSD PCBA.	Ensure all cables from the configuration plate to the VSD PCBA are connected. Cable going to P20 on VSD PCBA is most likely to cause problem.	Replace VSD PCBA.		
GRD LIMIT ERROR	Unit must be reconfigured as a TreadClimber.	Press [CLEAR]. Go to Change Machine Mode (Speed Increase, 8, Enter, Enter), then scroll to "TreadClimber" using the Speed Increase and Speed Decrease keys.			

ELECTRONIC TROUBLESHOOTING SUMMARY

3. Operational Error Codes	What this means	First Action	Second Action	Third Action	Fourth Action
GRD MOVE ERROR	Unit must be reconfigured as a TreadClimber.	Press [CLEAR]. Go to Change Machine Mode (Speed Increase, 8, Enter, Enter), then scroll to "TreadClimber" using the Speed Increase and Speed Decrease keys.			
MULTIPLE KEY	Message appears during the Service Test KEY TEST, if two keys are held down simultaneously or if a key is pressed while another key is stuck closed.	If possible, press [CLEAR], then go to Diagnostic Mode (Speed Increase, 6, ENTER), then scroll to "Key Test" using the Speed Increase and Speed Decrease keys. Press each key to identify which key is stuck.	If problem persists, open rear console access panel. Disconnect main keyboard cable from Processor board, and connect an alternate known-good key panel. Determine whether keys are now operable. If the alternate key panel works, replace the key panel.	Disconnect ROC key panel cable, determine whether problem persists. If problem goes away with ROC (Ergo) key panel disconnected, check Ergo cable. Plug alternate Touchsensor key panel and check operation. Replace either ROC cable or key panel as required.	Replace P51 Processor PCBA.
NOT DEFINED, then DRIVE POWER ERROR	Message appears when Pin 10 of the communication cable between the P51 Processor and VSD PCBAs are open.	Replace Communication cable which connects J10 on P51 Processor PCBA on VSD PCBA.	Replace VSD PCBA.	Replace P51 Processor PCBA.	
NTM CONFIG RQRD	This error indicates that the P51 Processor PCBA was manufactured for a non-Treadmill product such as an elliptical, stepper or bike.	Replace P51 Processor with one manufactured for use in Treadmills or TreadClimbers.			
OUT CUR ERROR	Walkbelt motor current is too low.	Ensure motor is connected to VSD PCBA. Cycle power and see if problem self-clears.	Replace VSD PCBA.	Replace Drive Motor.	
SYS OVRD ERROR	Walkbelt motor current is too high or walkbelt motor thermal switch has opened due to a motor overload.	This error is usually caused by excessive drag or friction on the deck. Closely inspect the deck and look for signs of excessive wear. If needed replace the belt and deck.	Let walkbelt motor cool down and cycle power. Motor thermal switch may open due to worn belt and deck.	Replace VSD PCBA.	Replace Drive Motor.

ELECTRONIC TROUBLESHOOTING SUMMARY

3. Operational Error Codes	What this means	First Action	Second Action	Third Action	Fourth Action
TC/TM CONFIG RQRD	Unit must be reconfigured as either a Treadmill or TreadClimber or VSD PCBA has wrong jumper configuration.	Press [CLEAR]. Go to Change Machine Mode (Speed Increase, 8, Enter, Enter), then scroll to appropriate configuration using the Speed Increase and Speed Decrease keys, then press ENTER.	Ensure jumpers on VSD are correct. TreadClimbers should have all three jumpers in place on PC0, PC3 and PC5.		
TM COM ERROR	Treadmill or TreadClimber communications error. Means P51 Processor PCBA can't talk serially to VSD PCBA.	Cycle power and see if problem self-clears.	Replace communication cable between P51 Processor PCBA and VSD PCBA.	Replace VSD PCBA.	Replace P51 Processor PCBA.

WIRING SCHEMATIC

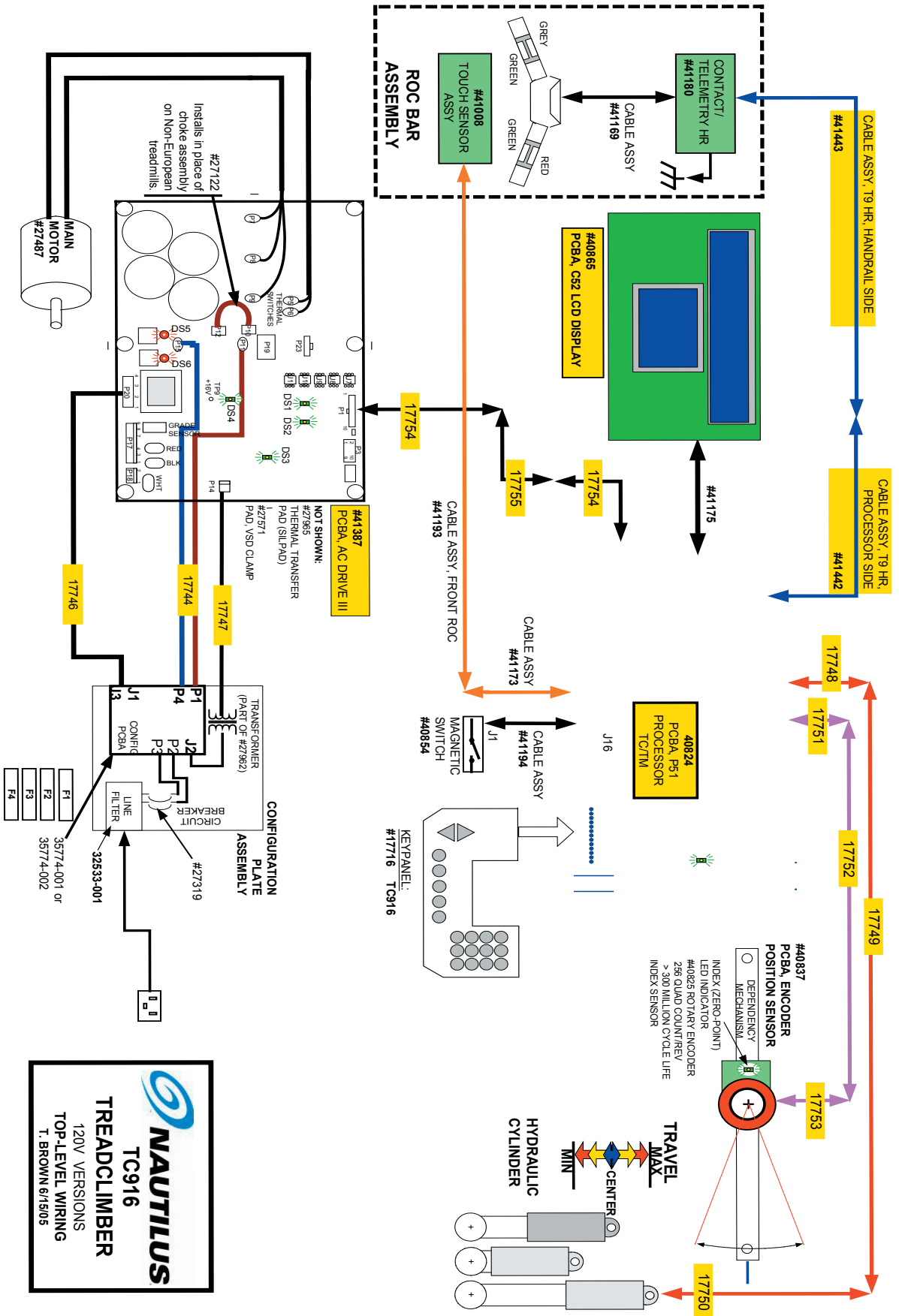

WIRING SCHEMATIC

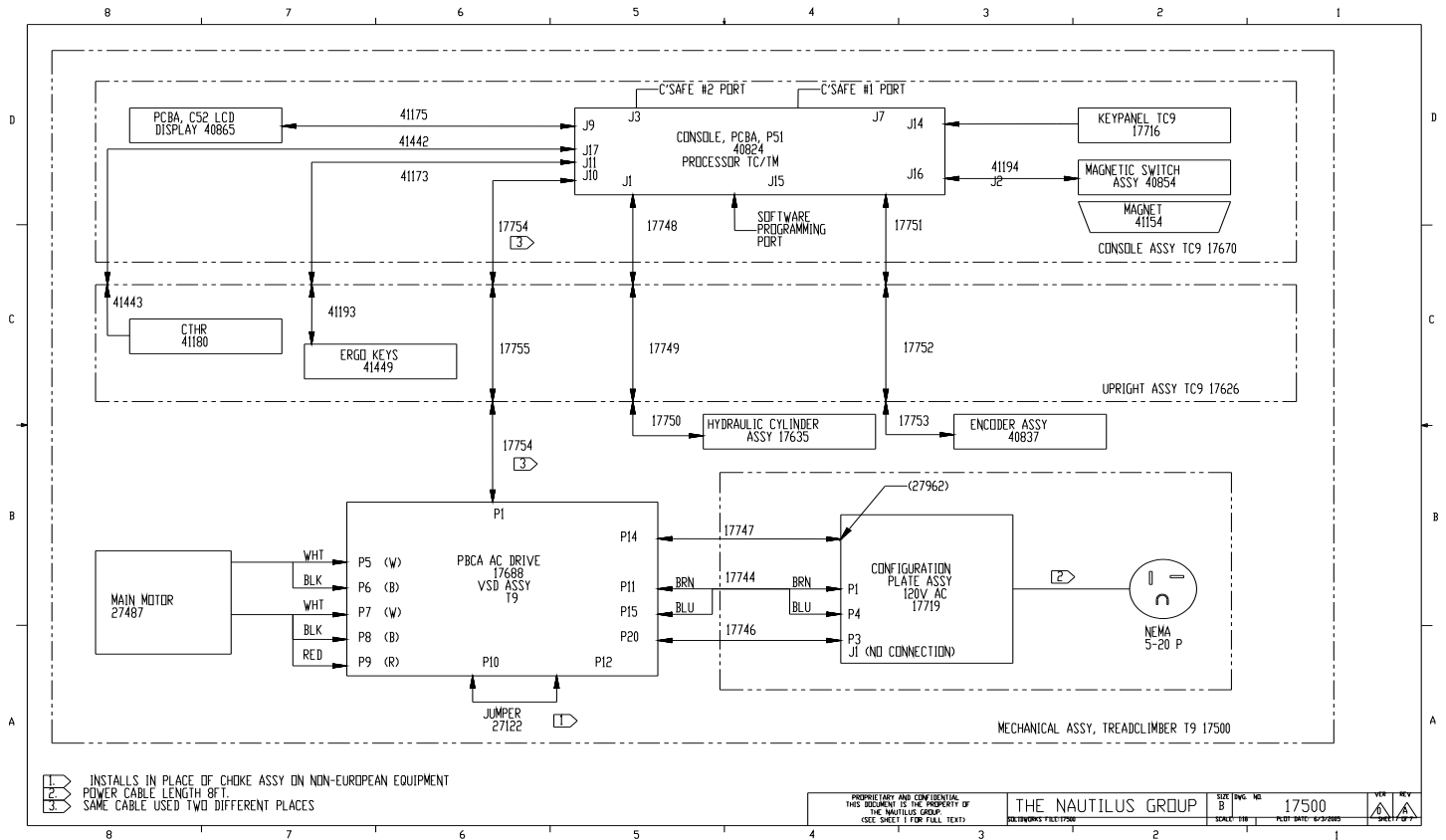

WIRING SCHEMATIC: 110 VAC DOMESTIC

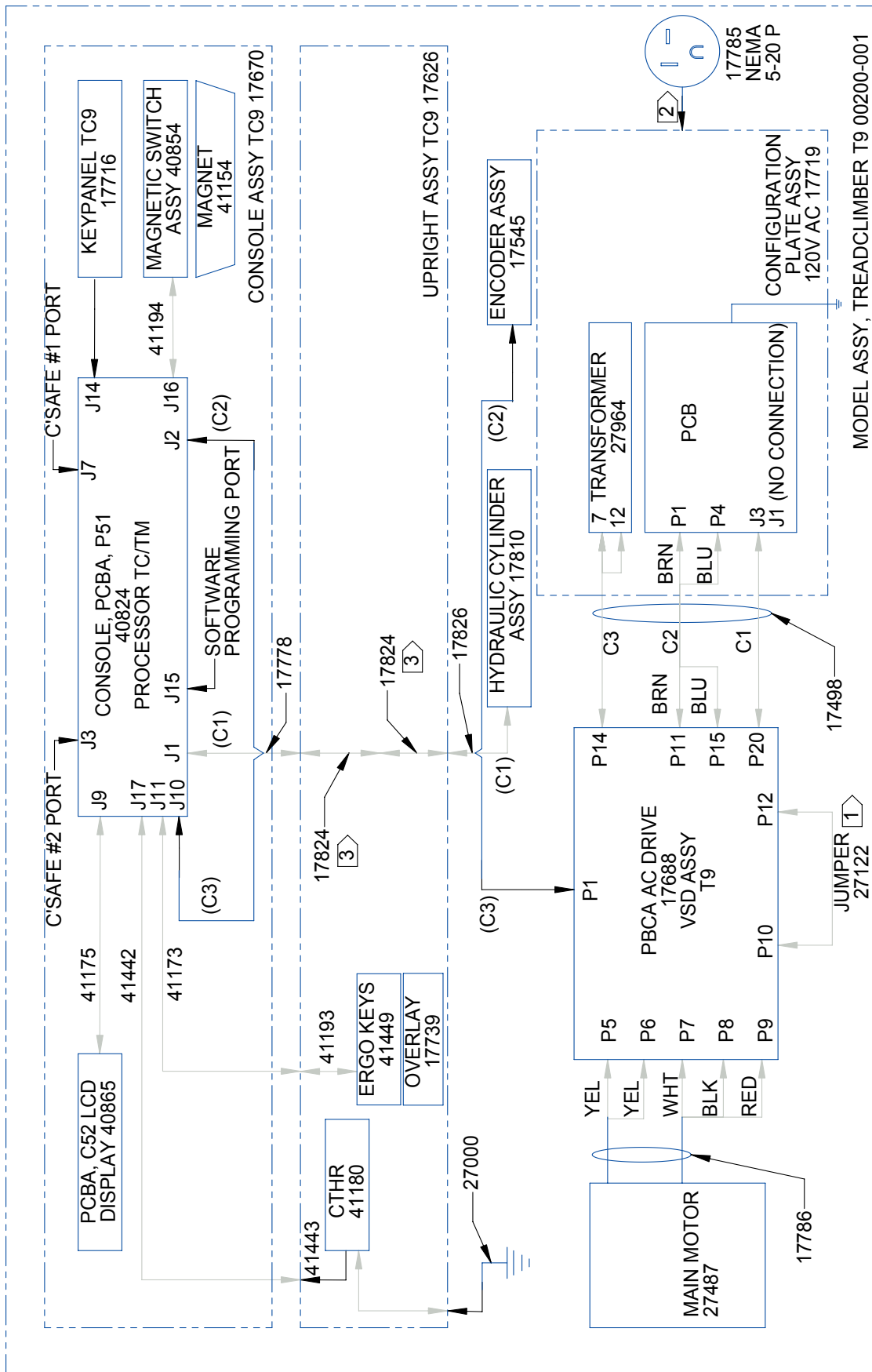

- 1. INSTALLS IN PLACE OF CHOKE ASSY ON NON-EUROPEAN EQUIPMENT
- 2. POWER CABLE LENGTH 12FT.
- 3. SAME TWO PLACES.
- 4. POWER CORD IS COUNTRY SPECIFIC ON INTERNATIONAL MODEL

WIRING SCHEMATIC: 230 VAC DOMESTIC

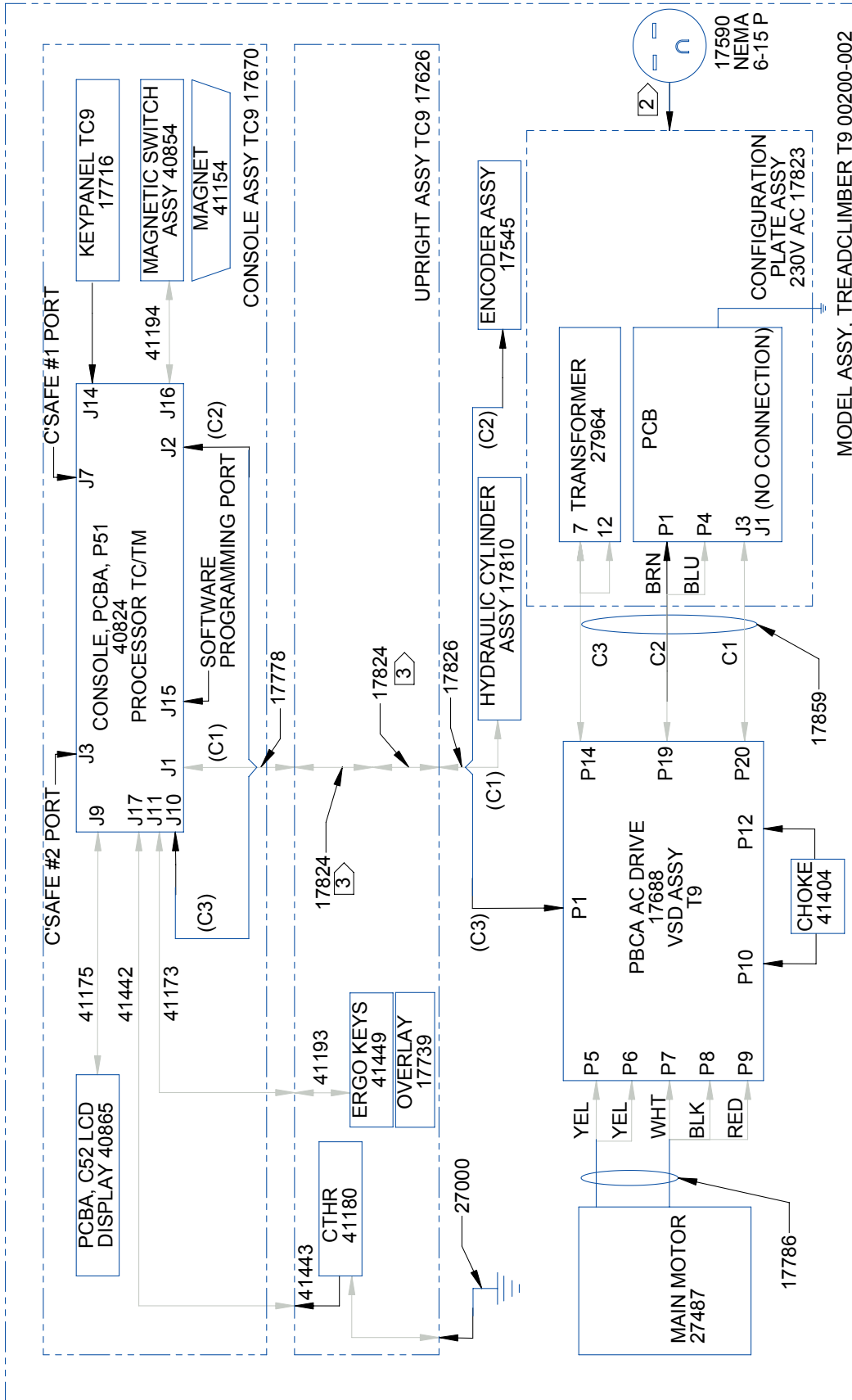

WIRING SCHEMATIC: 230 VAC INTERNATIONAL

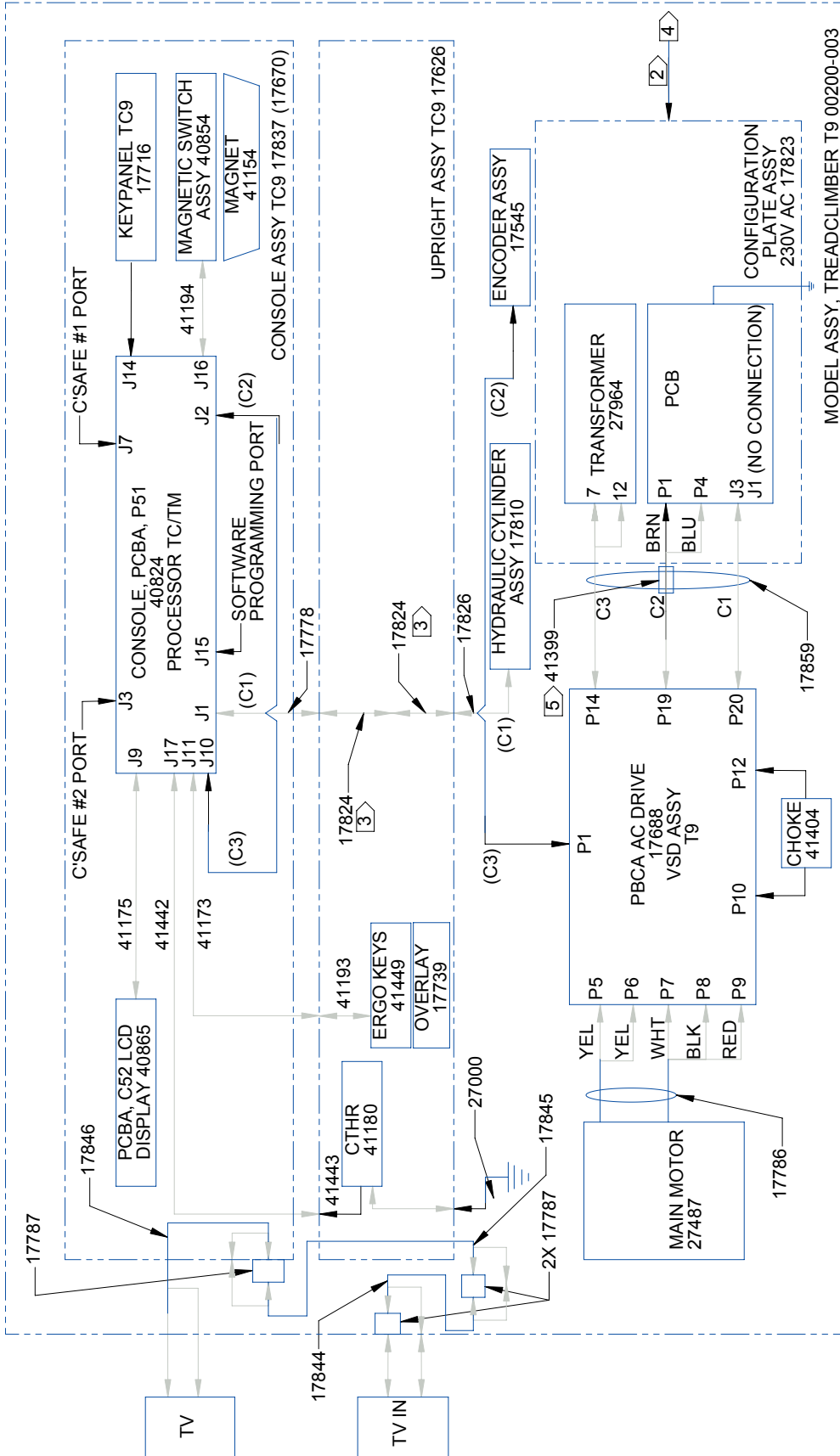

MODEL ASSY, TREADCLIMBER T9 00200-003

WIRING SCHEMATIC: 110 VAC DOMESTIC WITH TV

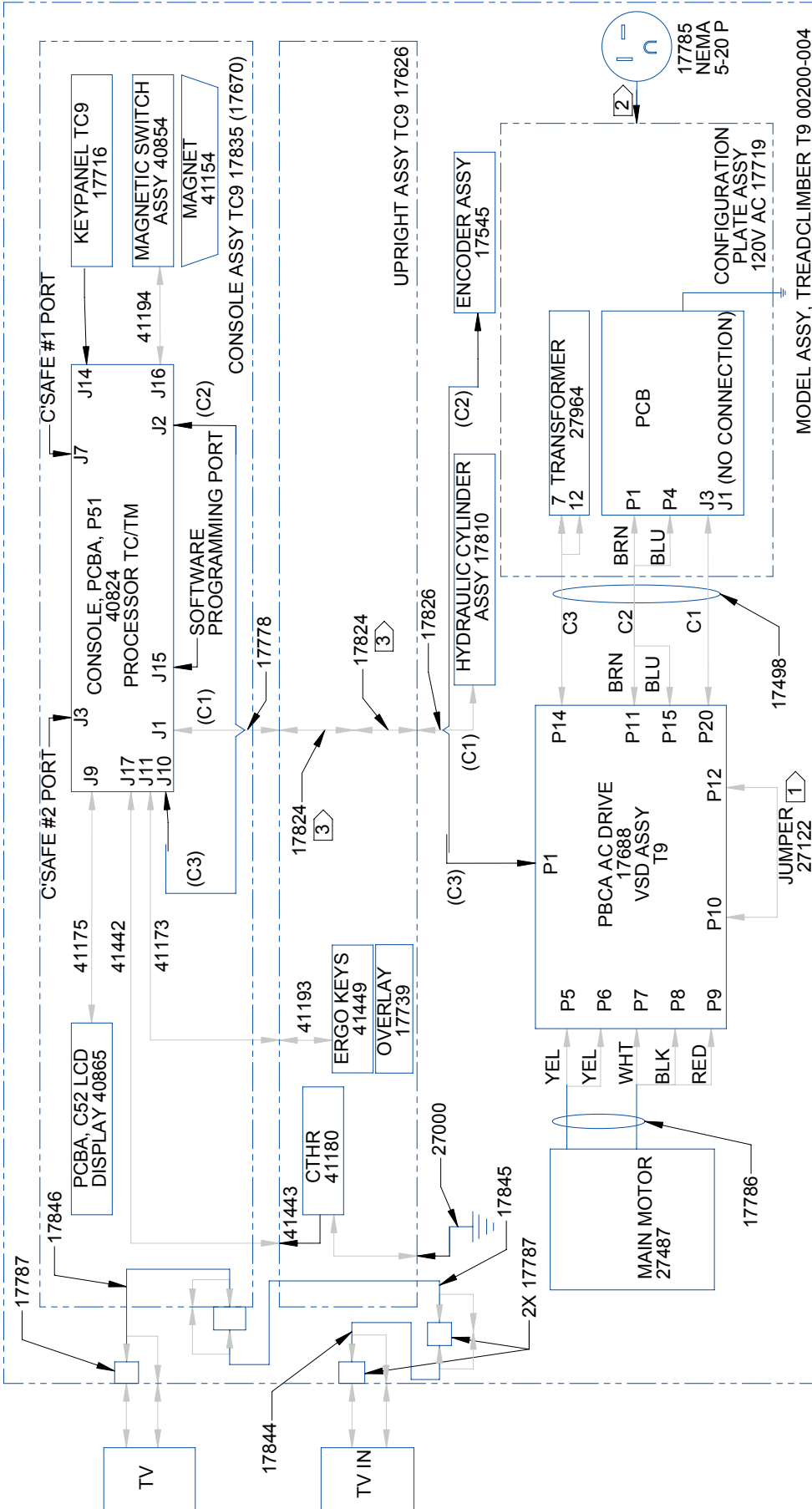

WIRING SCHEMATIC: 230 VAC DOMESTIC WITH TV

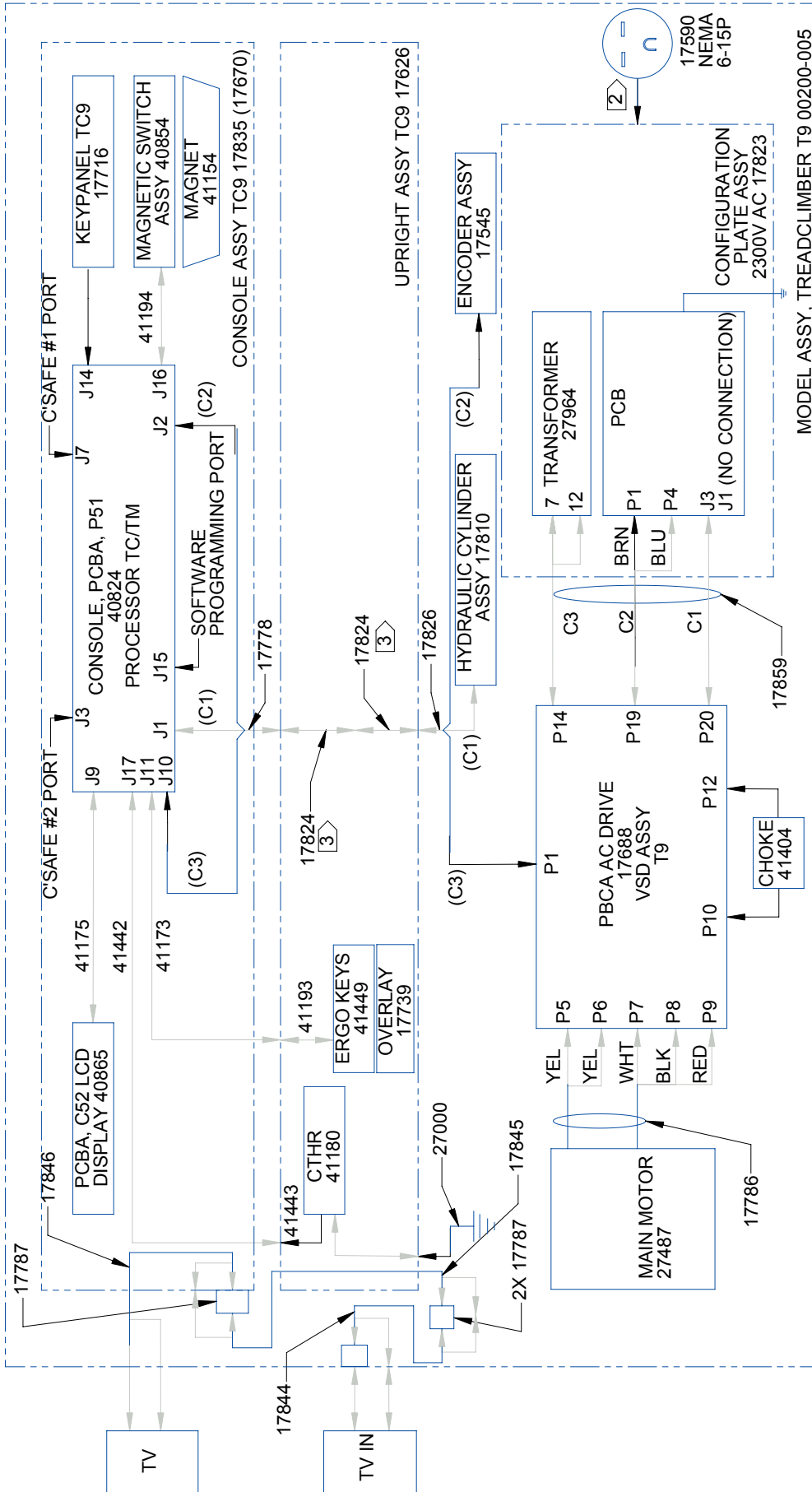

IMPORTANT CONTACT NUMBERS

If you need assistance, please have both the serial number of your machine and the date of purchase available when you contact the appropriate Nautilus office listed below.

OFFICES IN THE UNITED STATES:

E-mail: cstech@nautilus.com

- **NAUTILUS INNOVATION CENTER**
Nautilus, Inc.
1886 Prairie Way
Louisville, Colorado, USA 80027
Vancouver, Washington, USA 98683
Phone: 800-NAUTILUS (800-628-8458)
Email: customerservice@nautilus.com
Fax: 800-898-9410
- **TECHNICAL/CUSTOMER SERVICE**
Nautilus, Inc.
World Headquarters
16400 SE Nautilus Drive
Vancouver, Washington, USA 98683
Phone: 800-NAUTILUS (800-628-8458)
Email: customerservice@nautilus.com
Fax: 877-686-6466
- **CORPORATE HEADQUARTERS**
Nautilus, Inc.
World Headquarters
16400 SE Nautilus Drive
Vancouver, Washington, USA 98683
Phone: 800-NAUTILUS (800-628-8458)

INTERNATIONAL:

For technical assistance and a list of distributors in your area, please call or fax one of the following numbers.

- **INTERNATIONAL CUSTOMER SERVICE**
Nautilus International S.A.
Rue Jean Prouvé 6
1762 Givisiez / Switzerland
Tel: + 41-26-460-77-77
Fax: + 41-26-460-77-70
Email: technics@nautilus.com

BUSINESS OFFICES:

- **SWITZERLAND OFFICE**
Nautilus Switzerland S.A.
Tel: + 41-26-460-77-66
Fax: + 41-26-460-77-60
- **GERMANY and AUSTRIA OFFICE**
Nautilus GmbH
Tel: +49-2204-610-27
Fax: +49-2204-628-90
- **ITALY OFFICE**
Nautilus Italy s.r.l.
Tel: +39-031-51-10-86
Fax: +39-031-34-24-97
- **UNITED KINGDOM OFFICE**
Nautilus UK Ltd.
Tel: +44-1908-267-345
Fax: +44-1908-267-346
- **CHINA OFFICE**
Nautilus Representative Office
Tel: +86-21-523-707-00
Fax: +86-21-523-707-09

PAGE INTENTIONALLY LEFT BLANK



Model TC9.16



©2006. Nautilus, Inc. All rights reserved. Nautilus, the Nautilus Logo, ROC, TreadClimber, StairMaster and Changing the Game in Health and Fitness are either registered trademarks or trademarks of Nautilus, Inc. Polar and Fantastic are registered trademarks of their respective companies.

Nautilus, Inc. World Headquarters,
16400 SE Nautilus Drive, Vancouver, Washington, USA 98683
1-800-NAUTILUS www.nautilus.com